



PORTFOLIO

46

"Design is where science and art break even"
- Mieke Gerritzen

TABLE OF CONTENTS

<u>01</u>	STUDIO I	5
<u>02</u>	STUDIO II	13
<u>03</u>	DESIGN COMMUNICATION I	23
<u>04</u>	STUDIO III	27
<u>05</u>	ENVIRONMENTAL TECHNOLOGY I	37
<u>06</u>	DESIGN COMMUNICATION II	41
<u>07</u>	STUDIO IV	47

"What people want, above all, is order"
- Stephen Gardiner

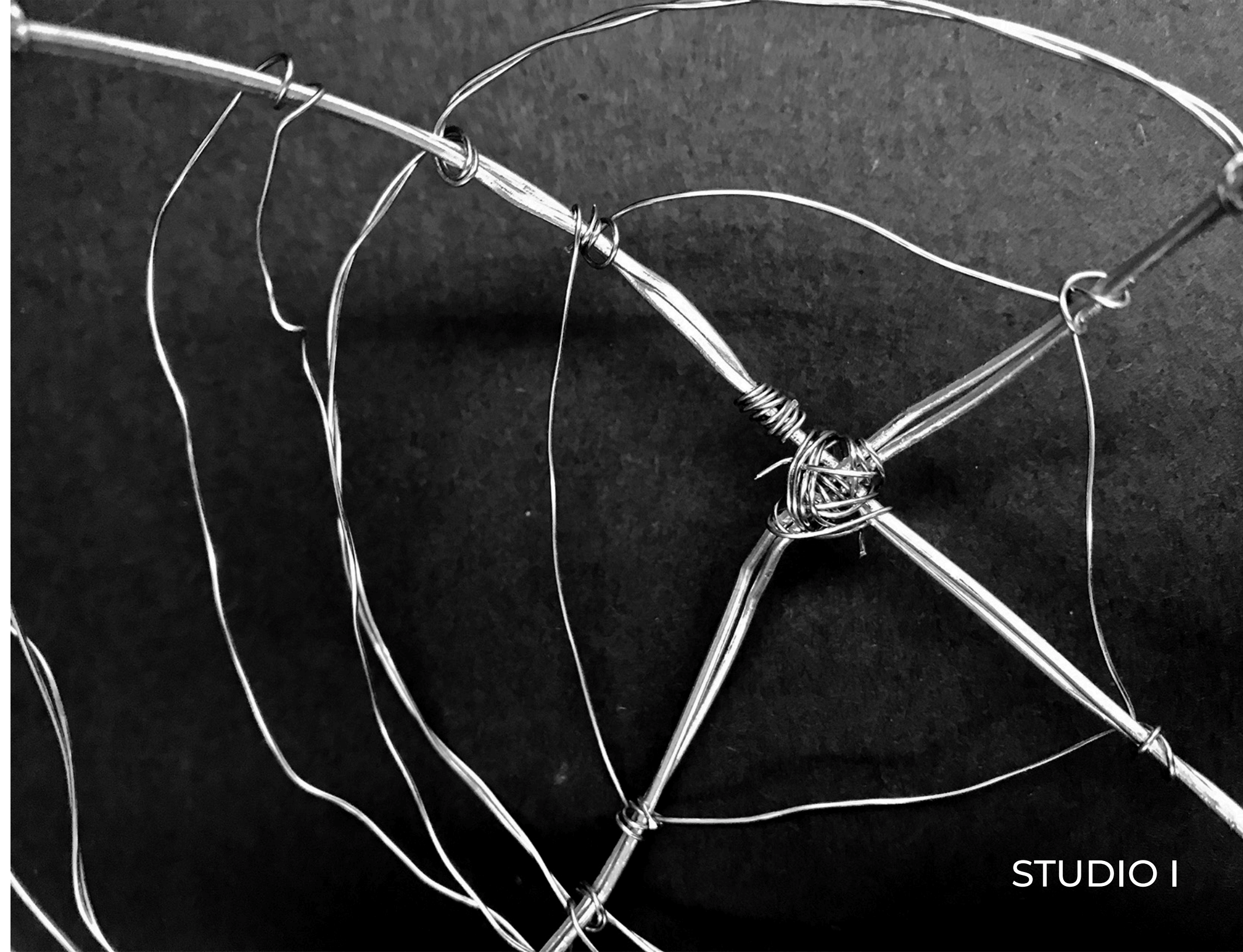

STUDIO I

Contour & Gesture Drawing

This module was designed to introduce us to students into the field of architecture. The exercise heightened the relationship between the eyes and hands. We were instructed to look at an object and draw on a sketch book in a continuous line, without looking down at the book.

The second exercise utilised the same process of the previous one and allowed a second method. The second method involved a different medium, charcoal. This medium was used to draw the body of a human showing movements.

The physical models were designed to show our interpretation of the contour and gesture drawings. The assigned medium was metal wire, which allowed for flexibility and better understanding of the material.

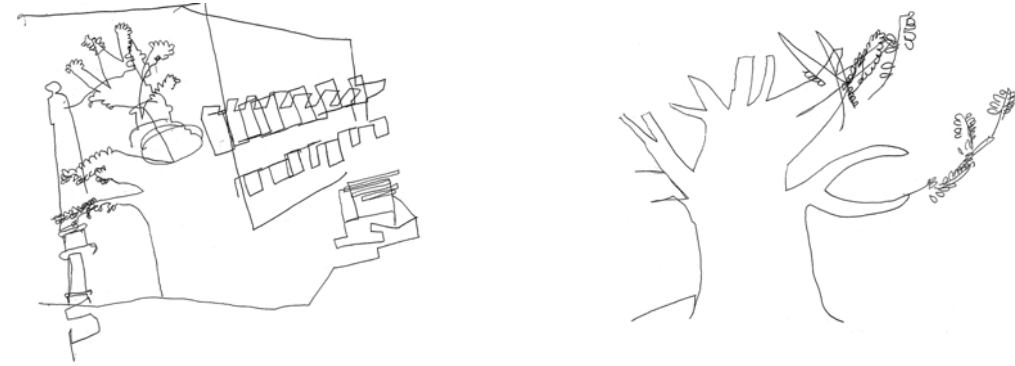

CONTINUOUS CONTOUR

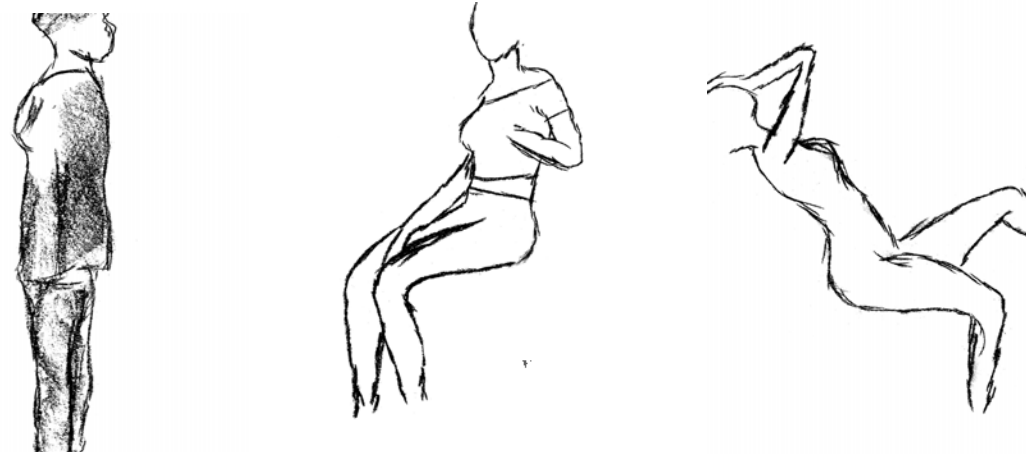

GESTURE DRAWINGS

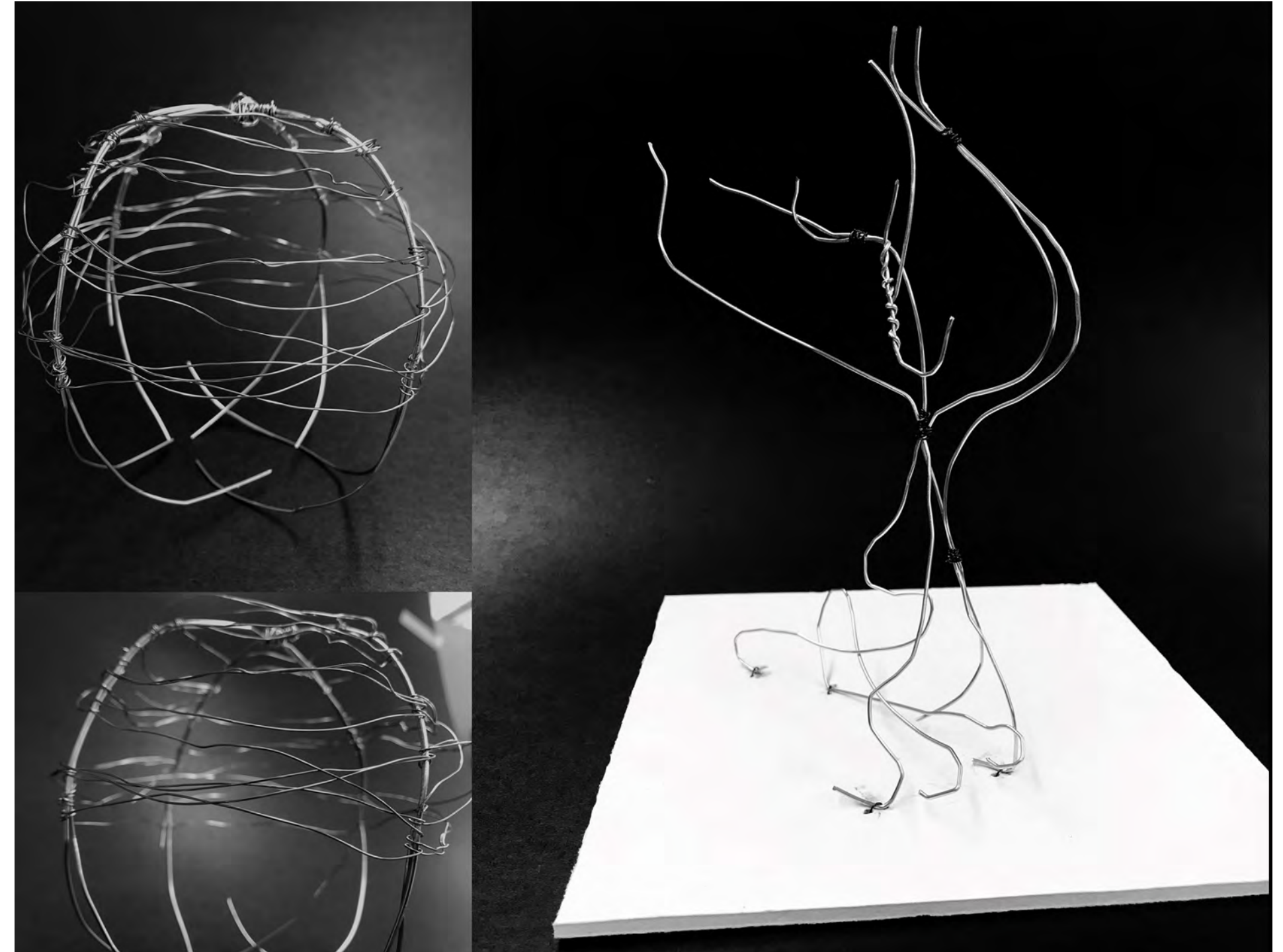

Tonal Study

This exercise used the dry medium charcoal to explore our environment in light and shadows. The medium was first explored by creating a gradient or tonal scale. For further exploration, an image of a water bottle casting a shadow was recreated with charcoal to show the shadow and highlights.

The last exploration was a physical model. Paper was cut into strips and colored according to the tonal scale. The colored strips of paper were folded in loop pattern and also arranged according to tones.



TONAL SCALE



TONAL DRAWING

TONAL MODEL



Regulating Lines

This project was designed to introduce the basic conventions of orthographic drawings in architecture. The chosen object of this project was a hair dryer. The object was drawn 2-dimensional and 3-dimensional. The understanding of line weights, angles, measure, drawing tools were developed.

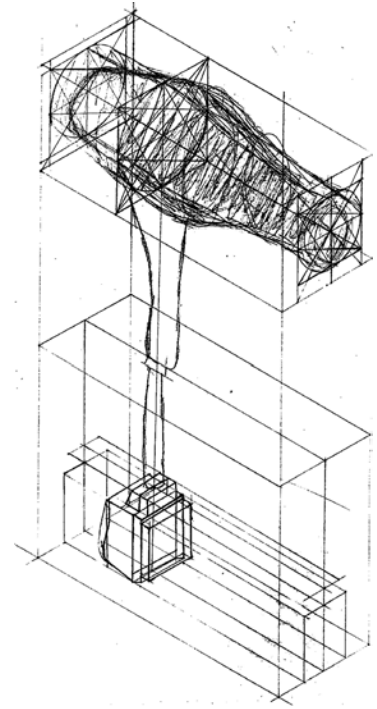
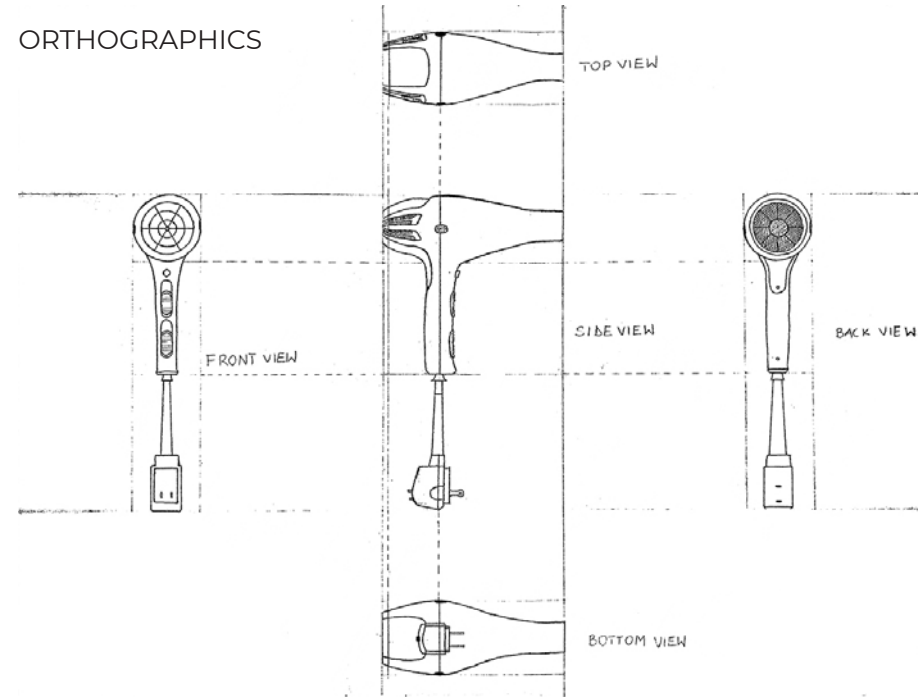

ISOMETRIC SKETCH

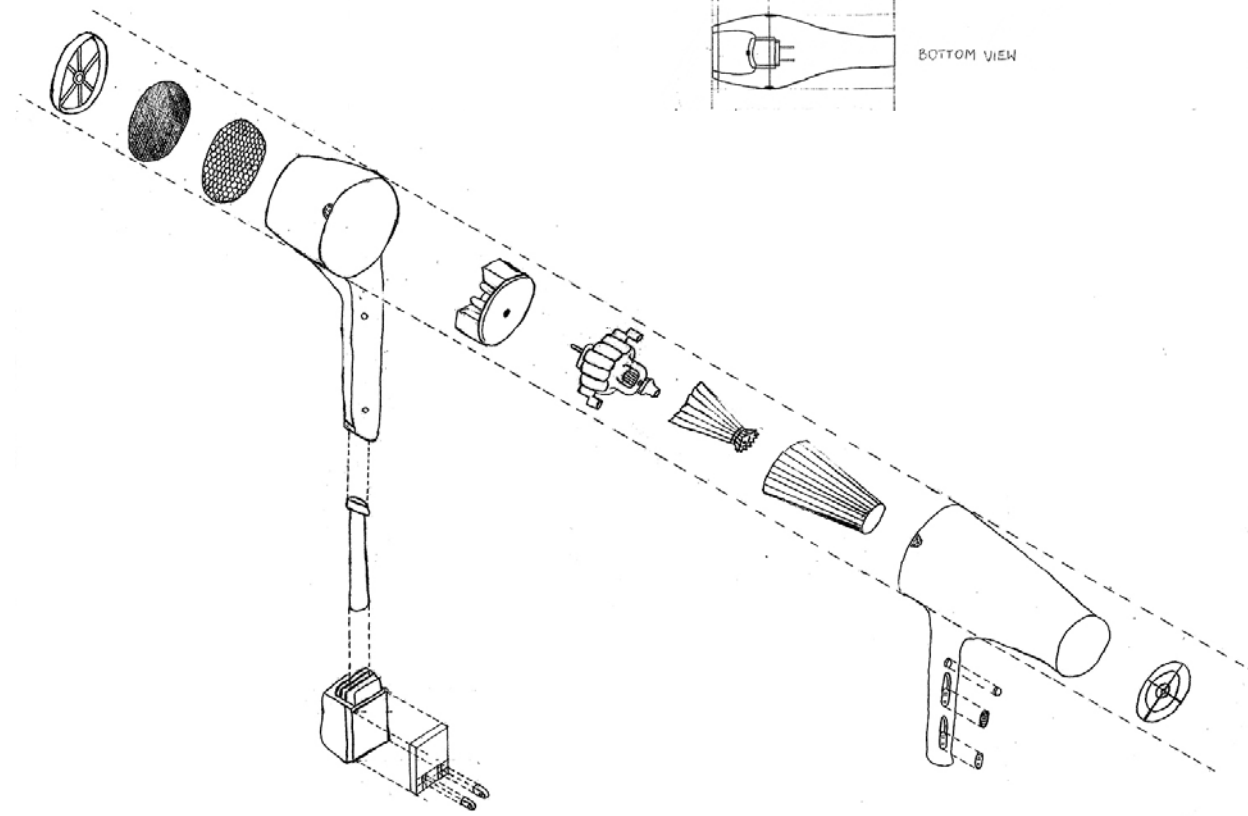

EXPLODED AXONOMETRIC

Pavilion

This is a personal space that uses the knowledge from past projects. The purpose of the pavilion is to create a personal space that allows the user to experience exterior and interior space simultaneously. The hemi-sphere shape and layered strip achieve this. The stripe filter light and display shadow that tells the time of the day. The strips support its own weight because of how it converges. The support under the benches create the illusion of it floating.

STUDY MODEL

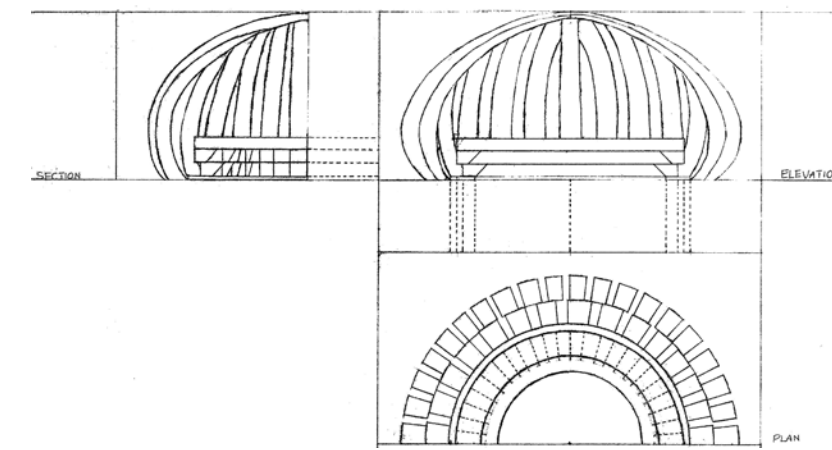
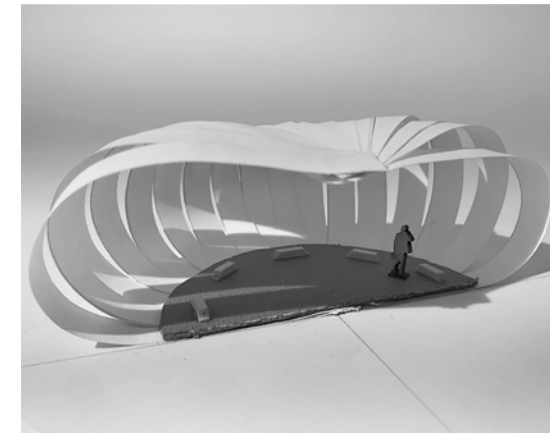

FINAL MODEL

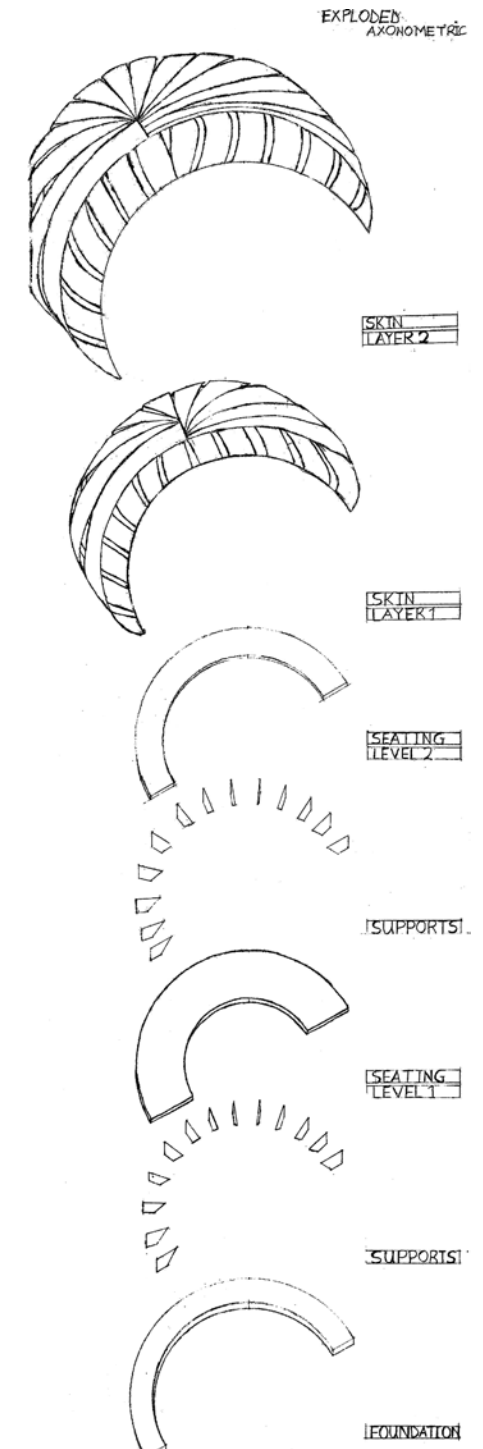
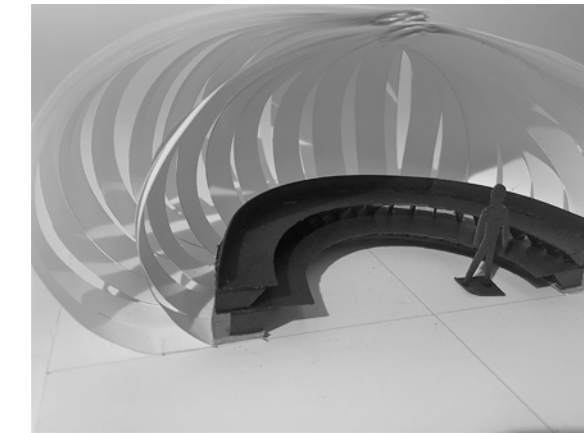
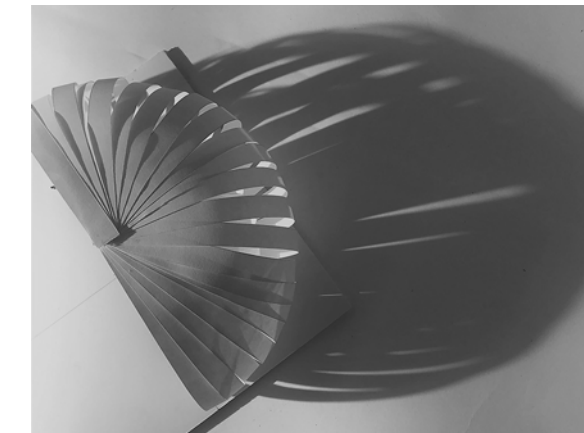

"The architect's role is to make the mythic real"
- Sotirious Kotoulas

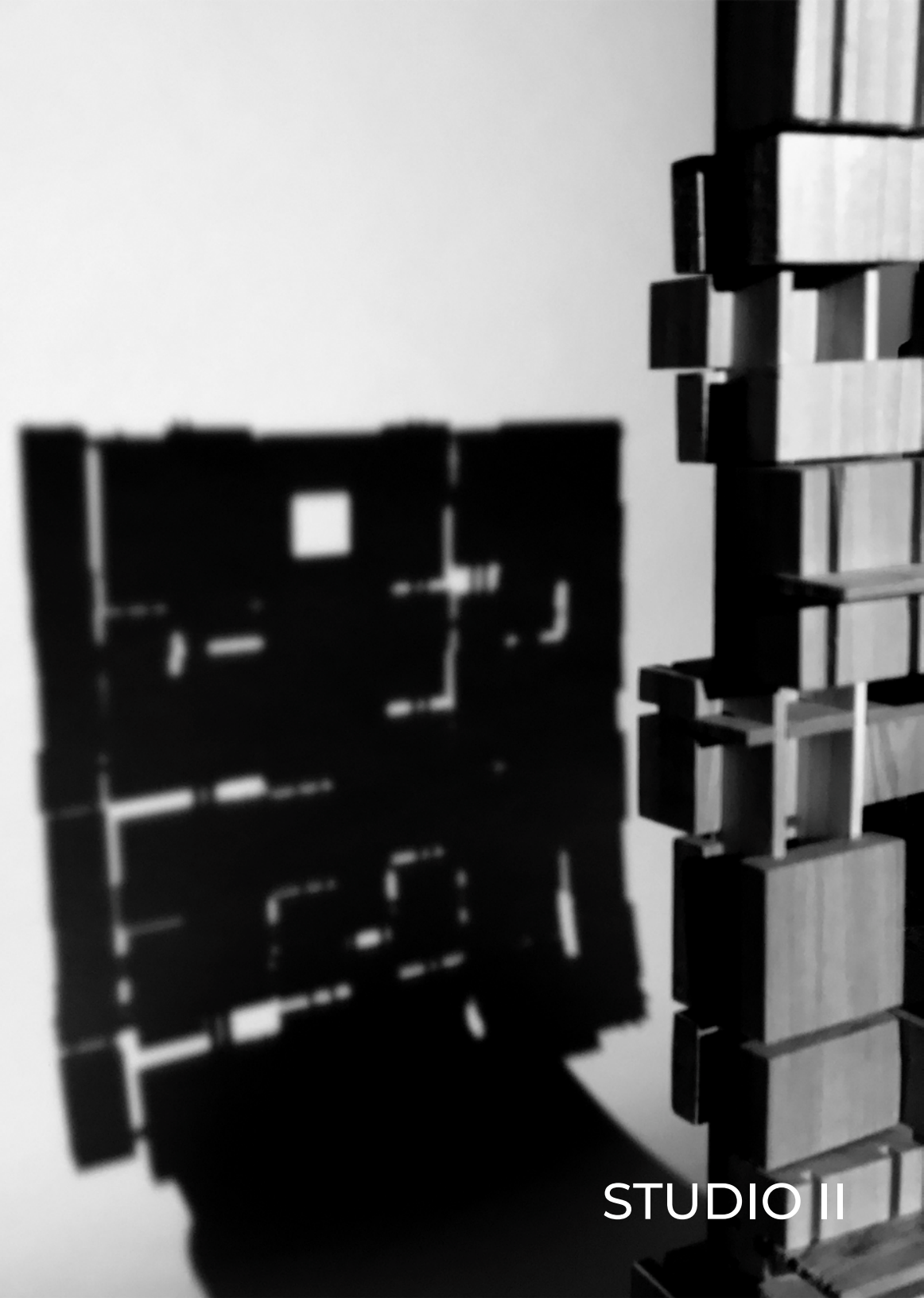

STUDIO II

Wood Tile Joinery

This project focused on wooden artifacts, joint methods and abstraction. The process began with finding and documenting a phenomena. The phenomena will be processed through abstraction to find its elements and the rules governing the elements. These findings will be interpreted refined into module through addition and subtraction.

The constraints of the module is a nine-square grid that measures 15"x15". The material for the physical model was poplar wood and a spline joinery. The abstraction of the phenomena developed into three grounds: foreground, middle-ground and background. The 3"x3" cube was integrated into the design to present a void.

Phenomenon abstraction

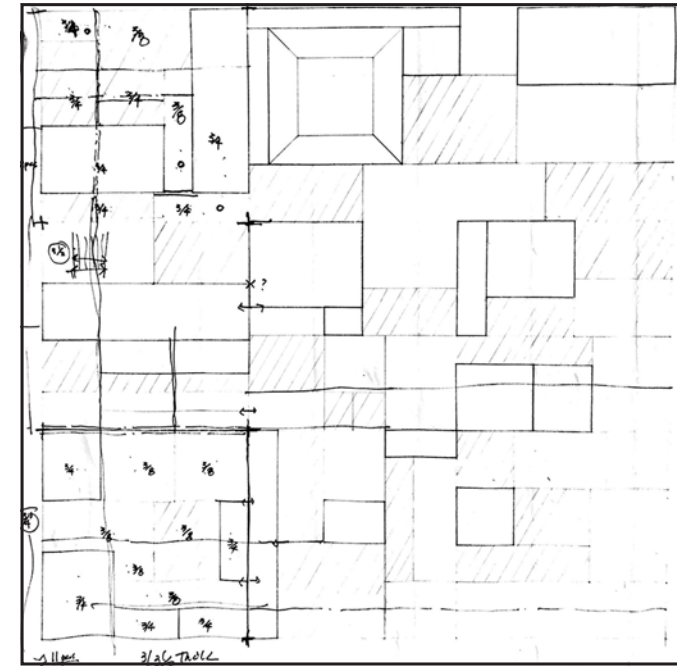
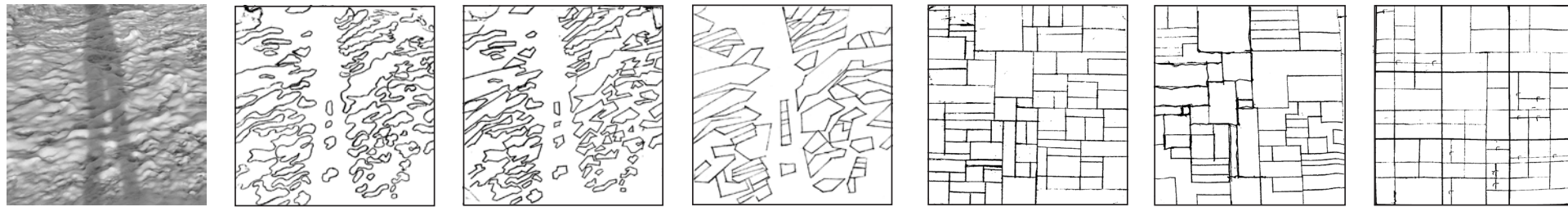

WOODEN ARTIFACT SKETCH

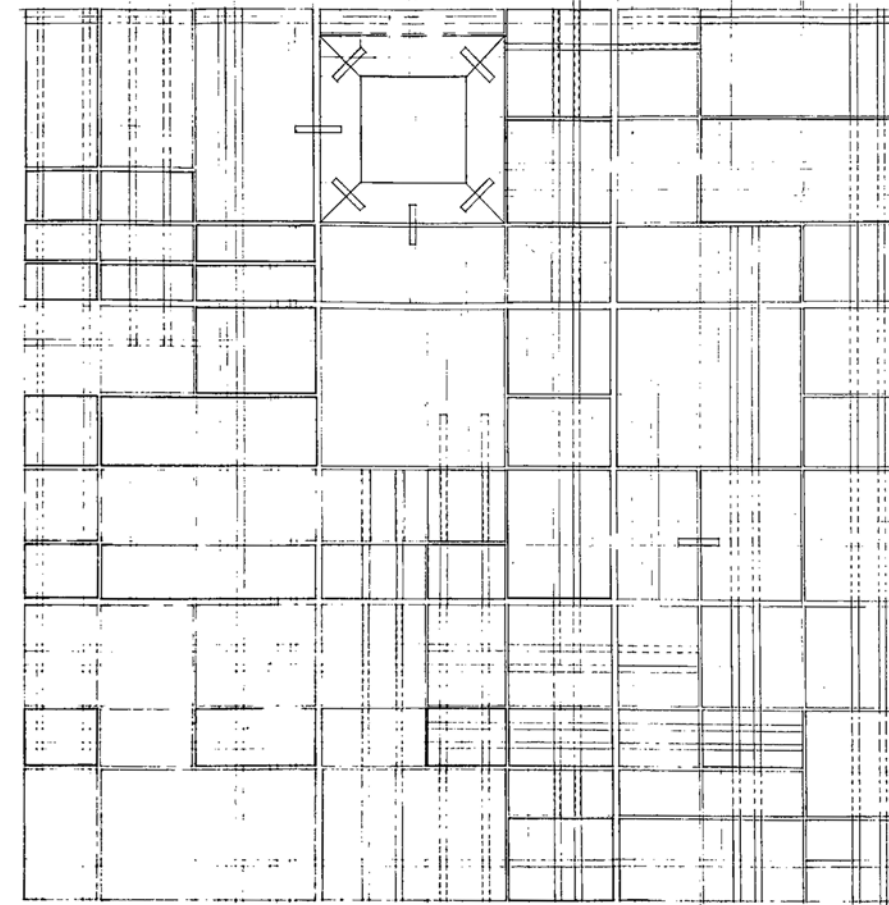

PLAN

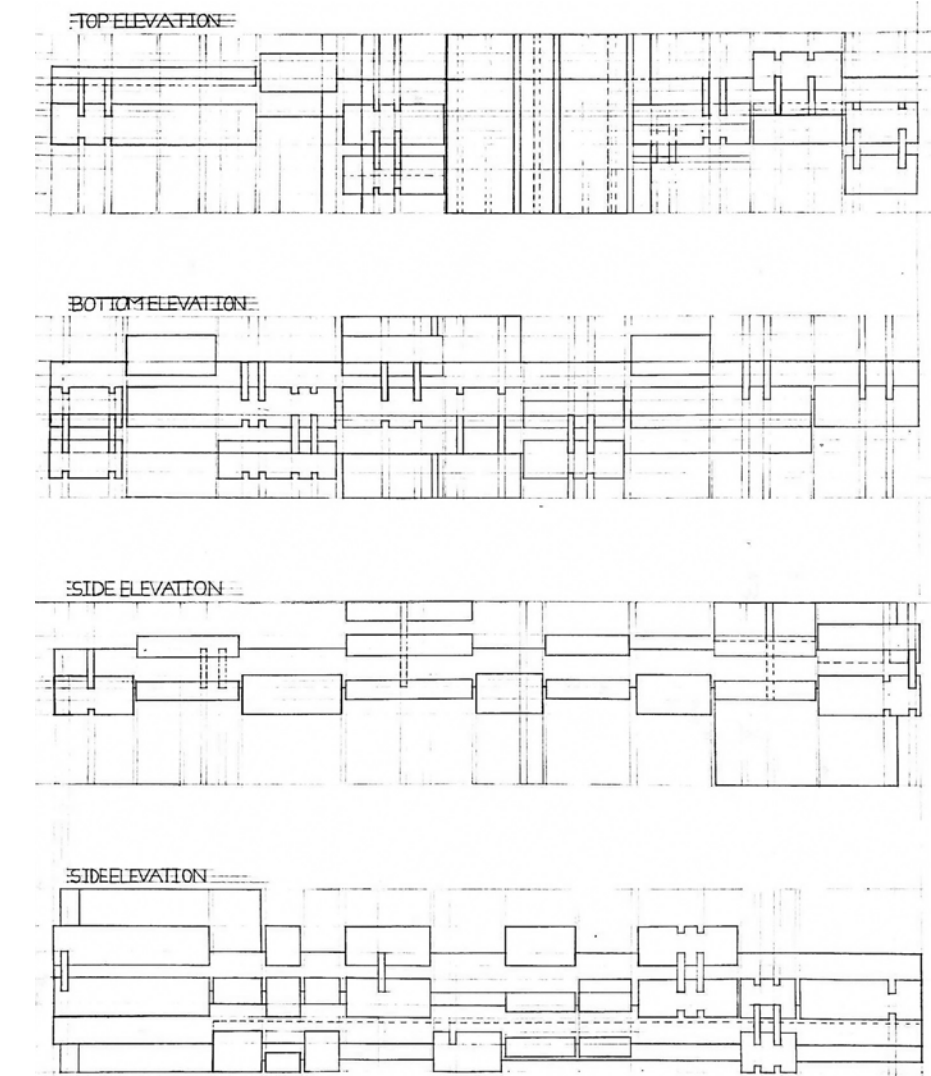

SCALE: 3"=1'-0"

ISOMETRIC

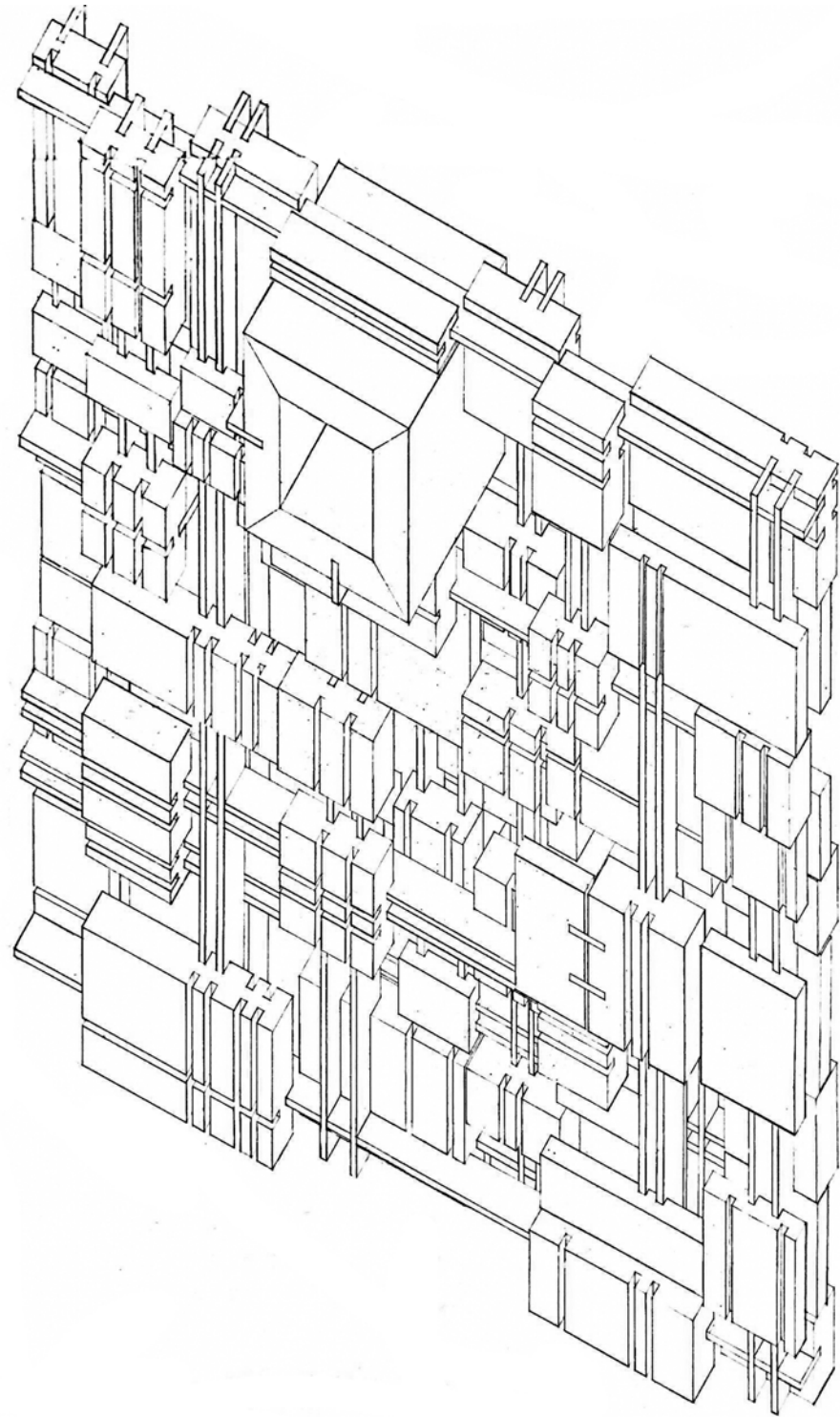

SECTION

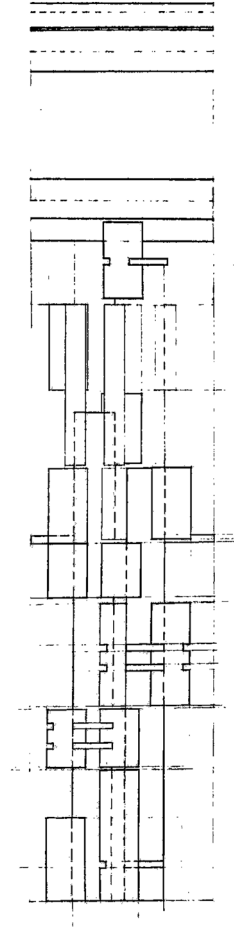

SECTION

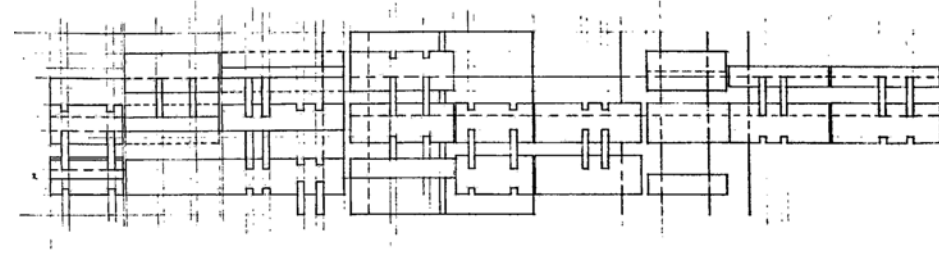

SCALE: 3"=1'-0"

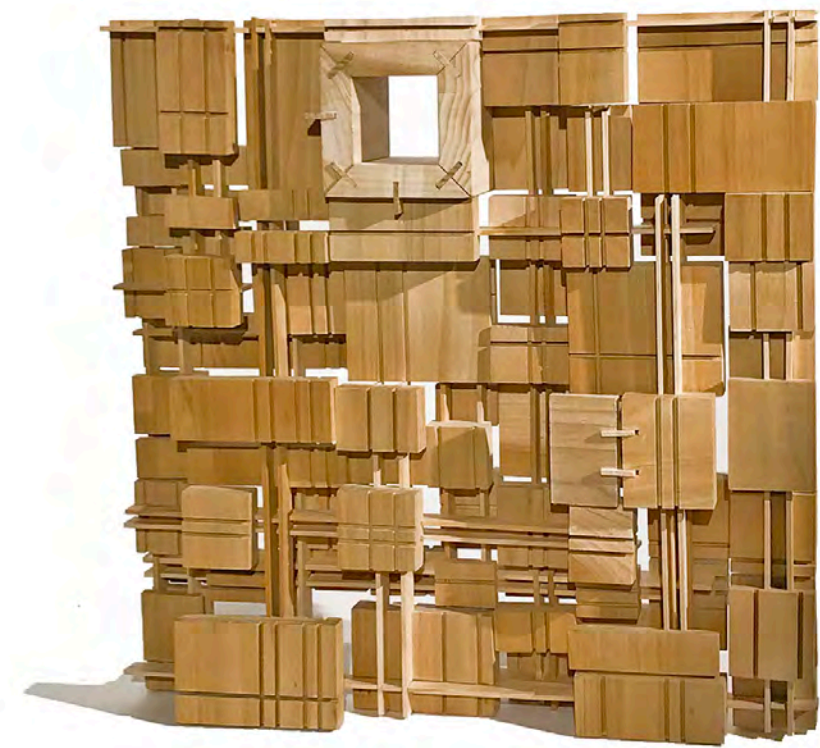

Bird Observation Tower

This is a precedent study and was assigned to a group of three students, I was one of them. The study is about the Bird observation tower in Heiligenhafen, Germany and was designed by gmp.von Gerkan & Marg and Partners Architects. The purpose of this tower was to observe birds in their own natural environment without interrupting. The structure looks like a sitting bird and provides a glassed-in observation tower for ornithologists and other visitors.

The study helped us to understand geometry, structure, construction drawings. In this project, I draw the sections, elevations and one plan. The analysis, plans and section isometric were drawn by the other group members. The materials used to make the physical model were chipboard, square dowels, poplar wood, and acrylic.



Diagram Analysis

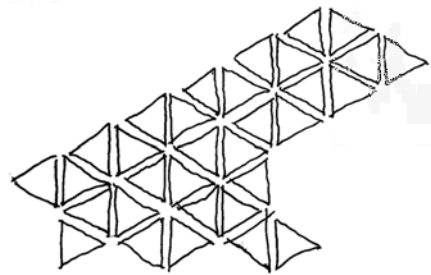

Equilateral Triangles
Formed between each support

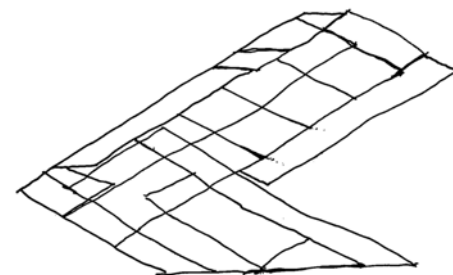

Parallelograms

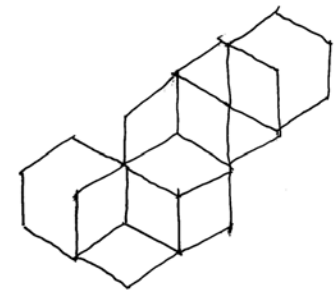

Hexagons
Overlaid forms geometric cubes

Orthographic Drawings

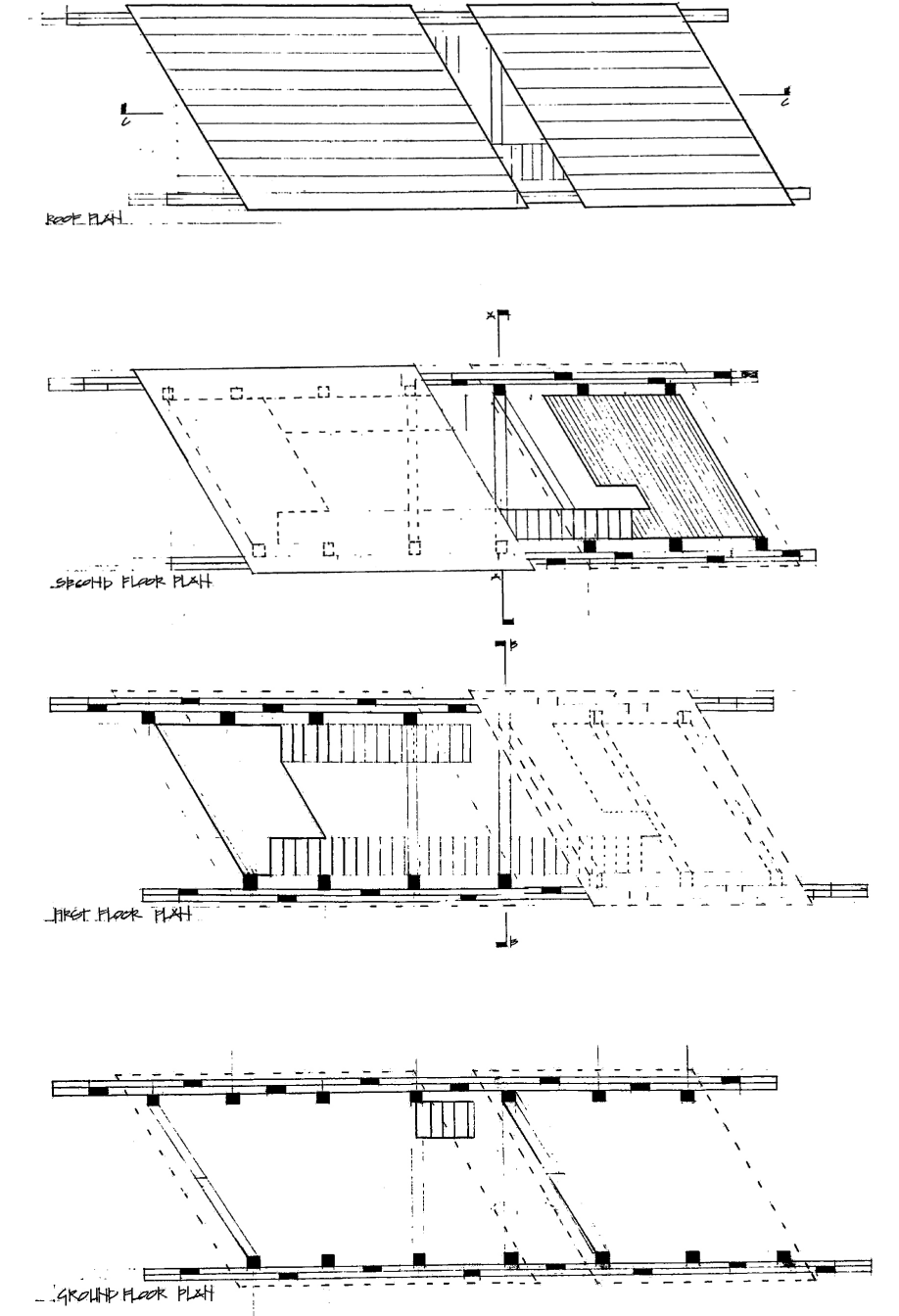
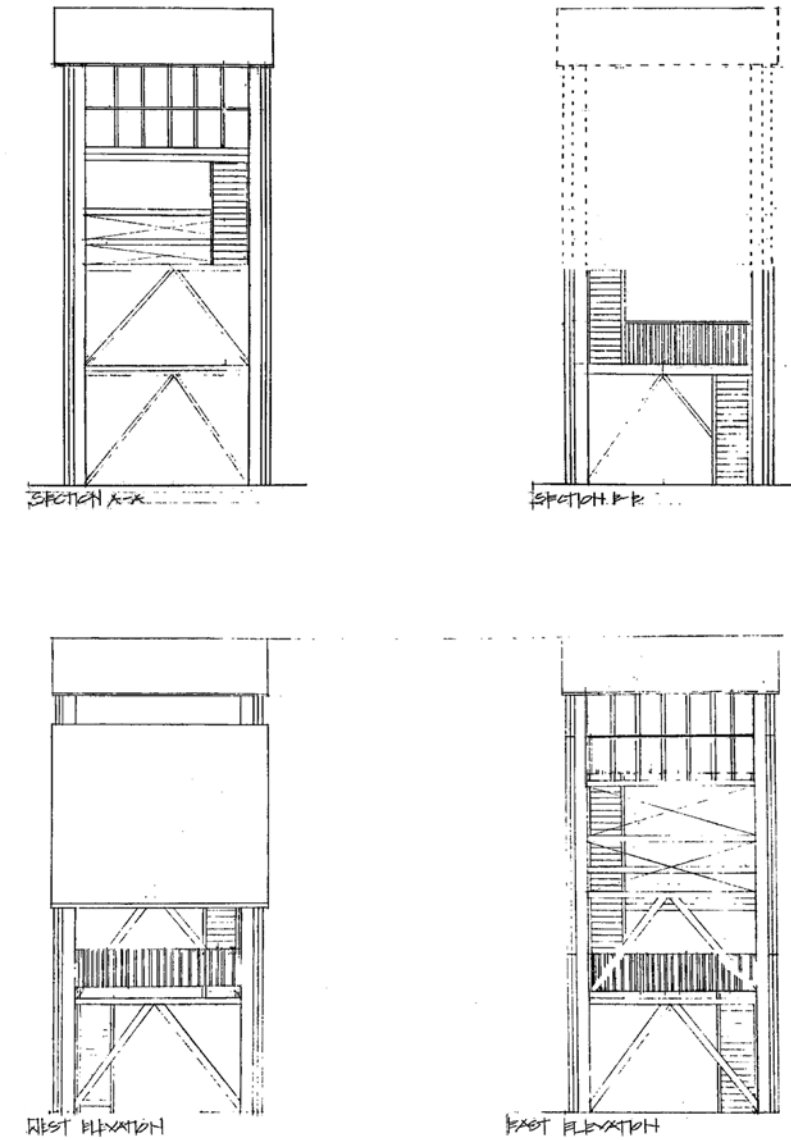

SCALE: 1/16"=1'-0"

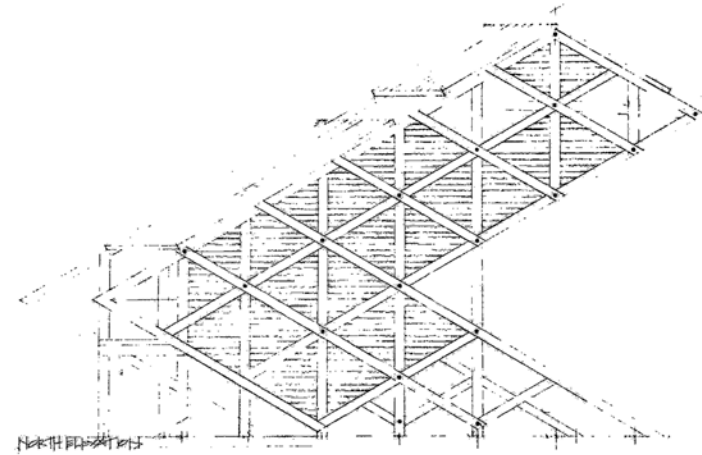
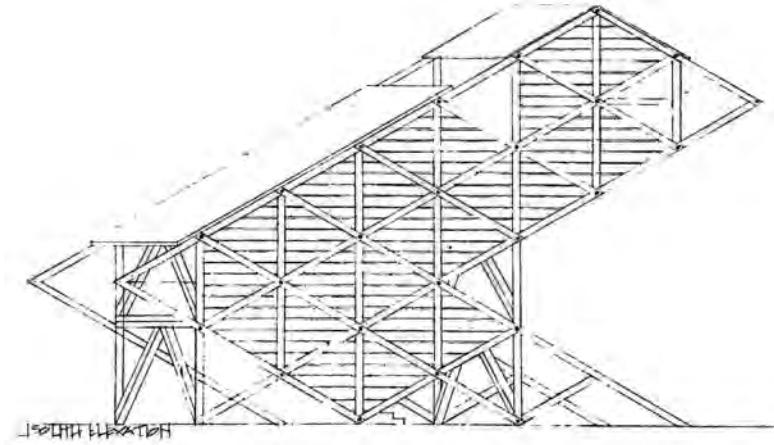
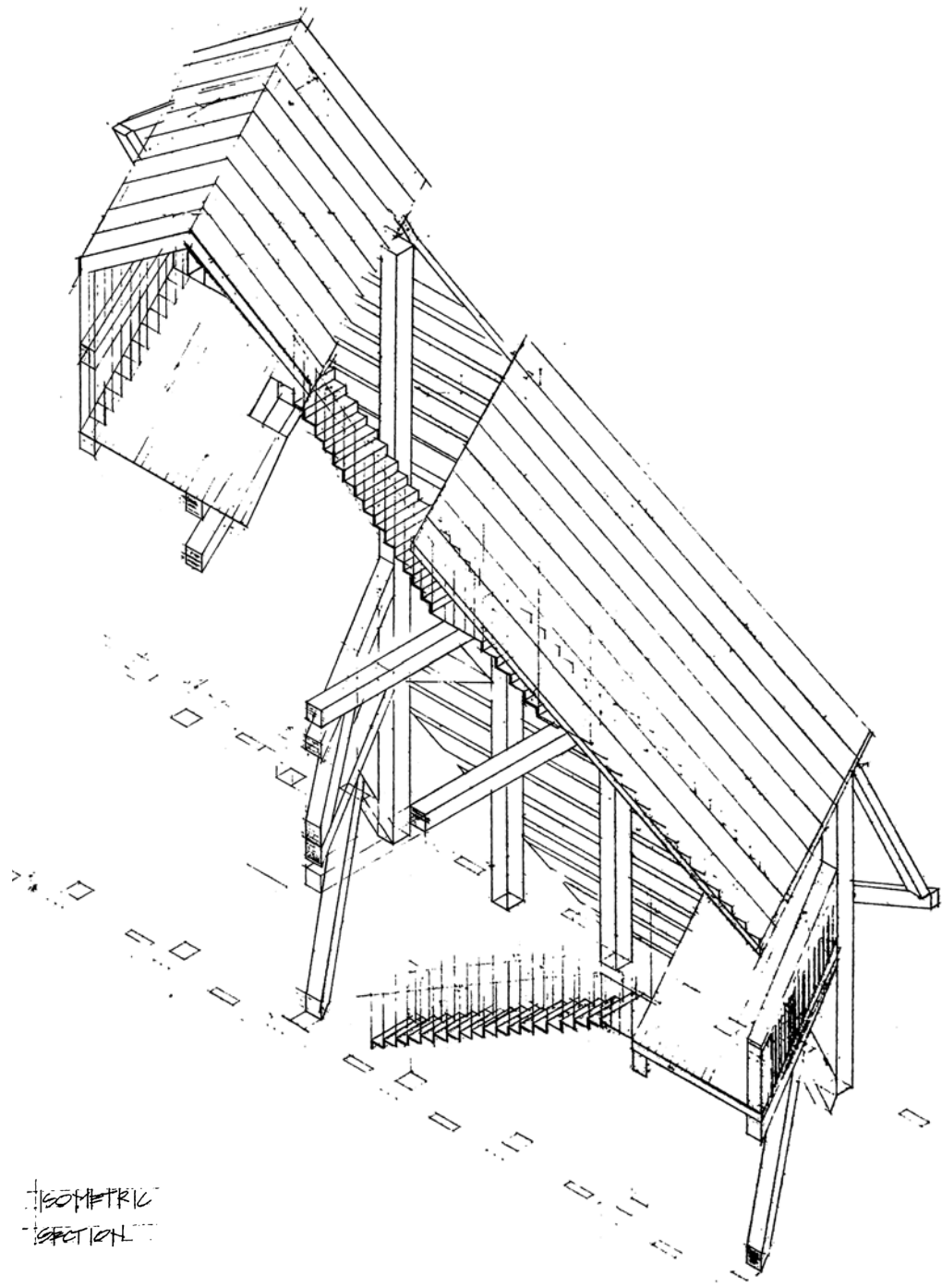

SCALE: 1/16"=1'-0"



"Architecture is an expression of values"
- Norman Foster



Chapel Ruhewald Schloss Tambach

This is a precedent study that was used to teach how to use Rhino 6, Adobe Illustrator, Adobe Photoshop and Adobe InDesign. It is a chapel in Coburg, Germany. It is placed in a forest cemetery and provides a space for meditation. It is a wooden construction and has a ar ches that rise to form the shape. The large window at the end of the Chapel creates an amazing view of the forest.

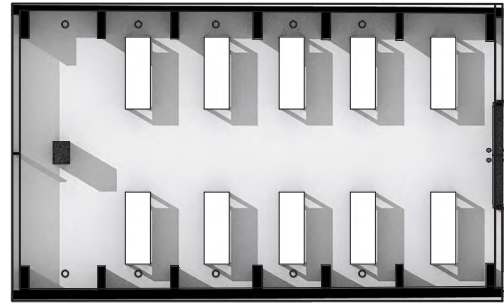

PLAN

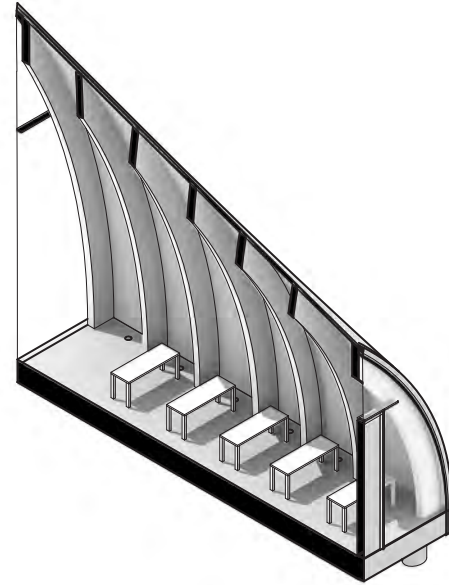

SECTION ISOMETRIC

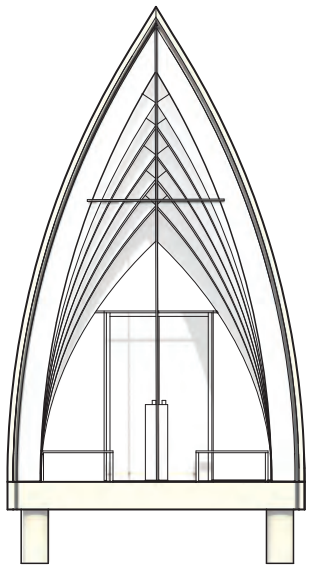

ELEVATION

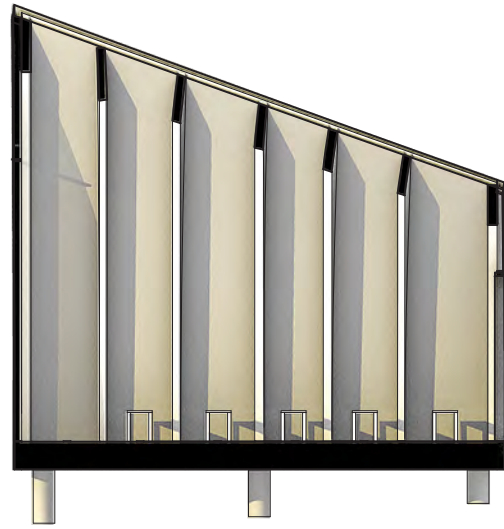

SECTION

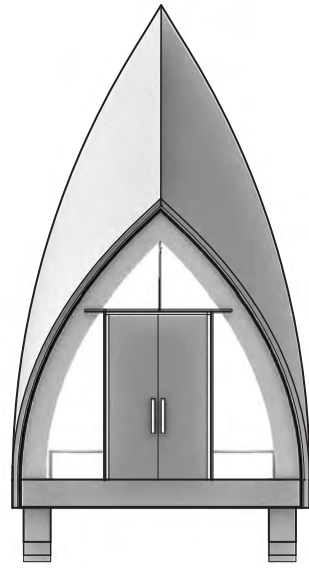

ELEVATION

SCALE: 3/32" = 1'-0"



"Architecture is an inhabited sculpture"
- Constantin Brancusi



STUDIO III

TWISTED HOUSE

This project is a residential building for a single family. The client is a married couple with one child. The client wanted personal space and natural light. The goal is to create a private space with open spaces.

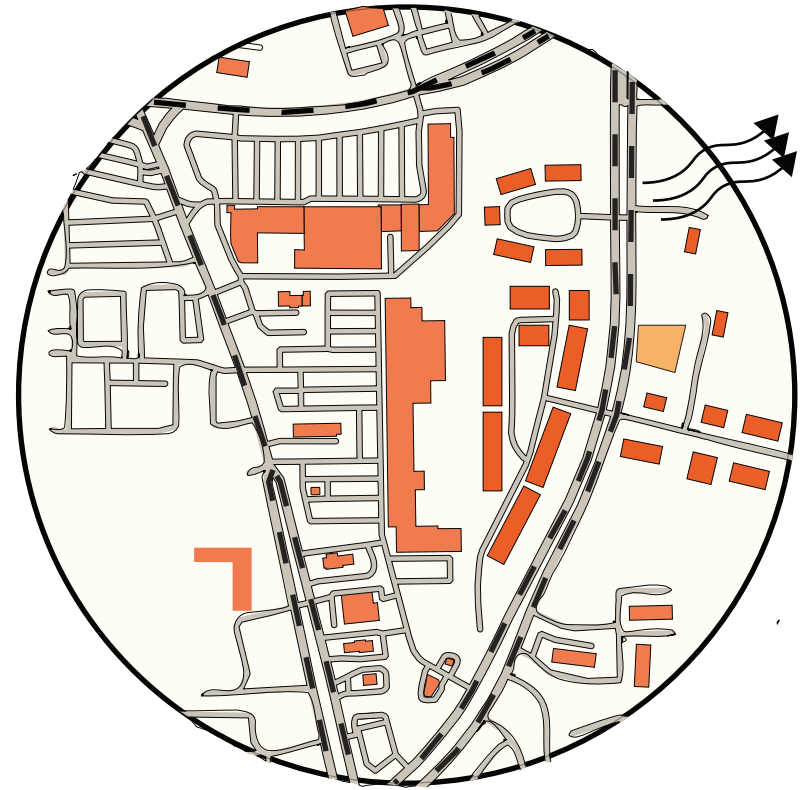

- RESIDENTIAL BUILDINGS ■
- COMMERCIAL BUILDINGS ■
- PROPOSED SITE ■
- MAJOR ROAD
- PREVAILING WINDS ↗

SITE ANALYSIS

The site is located at 1203 Terrel Mill Road, Marietta Georgia. It has a sloping topography and the road to the site is hidden by trees and bushes. There are two opportunities for road access and the best decision would be to use the hidden road because of the privacy it provides.



- ISOVISTS AROUND SITE ■
- ACCESS TO SITE →
- RESIDENTIAL BUILDINGS ■
- PROPOSED SITE ■

Program & Form Development

The precedent studies of this house are the Villa NM by UNStudio and the Twist museum by Bjarke Ingels. In the precedent studies, circulation between solids and definition of the transition spaces were major concepts. The twisted portion of the form will be the transition space between the volumes. The transition spaces connect to all parts of the house.

There will be three bedrooms: master bedroom, child's bedroom and the guest bedroom. The office space is next to the master bedroom for privacy. The master' and child's bedroom will have closet spaces to improve quality of living. Each bedroom has a bathroom to provide privacy to the house occupants instead of sharing like a conventional residential house.

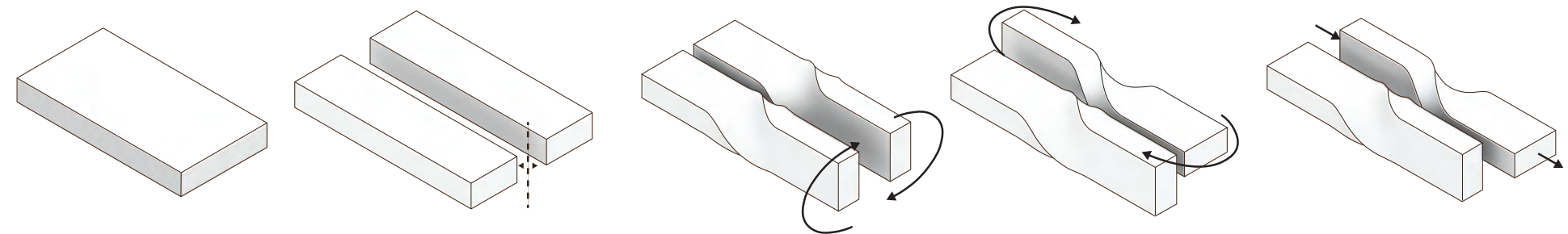
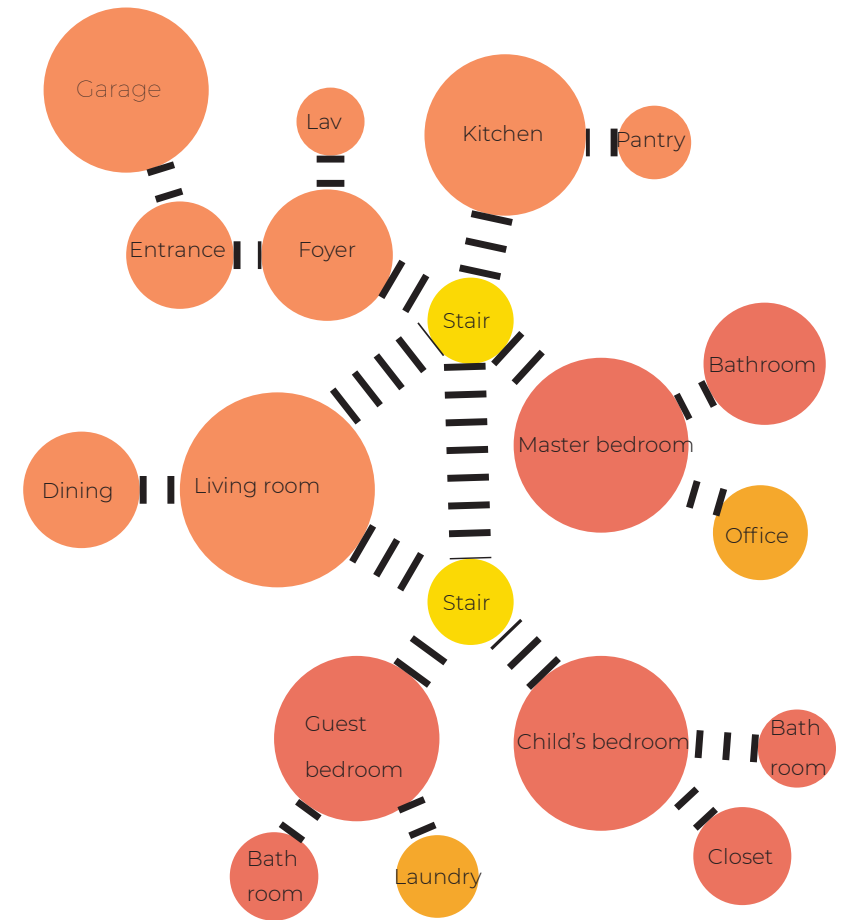

Whole Split Twist Rotate Forward

Design Development

The study models helped to better understand how the form will be placed on site and needed iterations. The first model shows the appropriate scale. The second model shows development on the occupiable spaces in the house. To solve the issue of a sloping topography, the vertical solids of the house will be supported by angled columns.

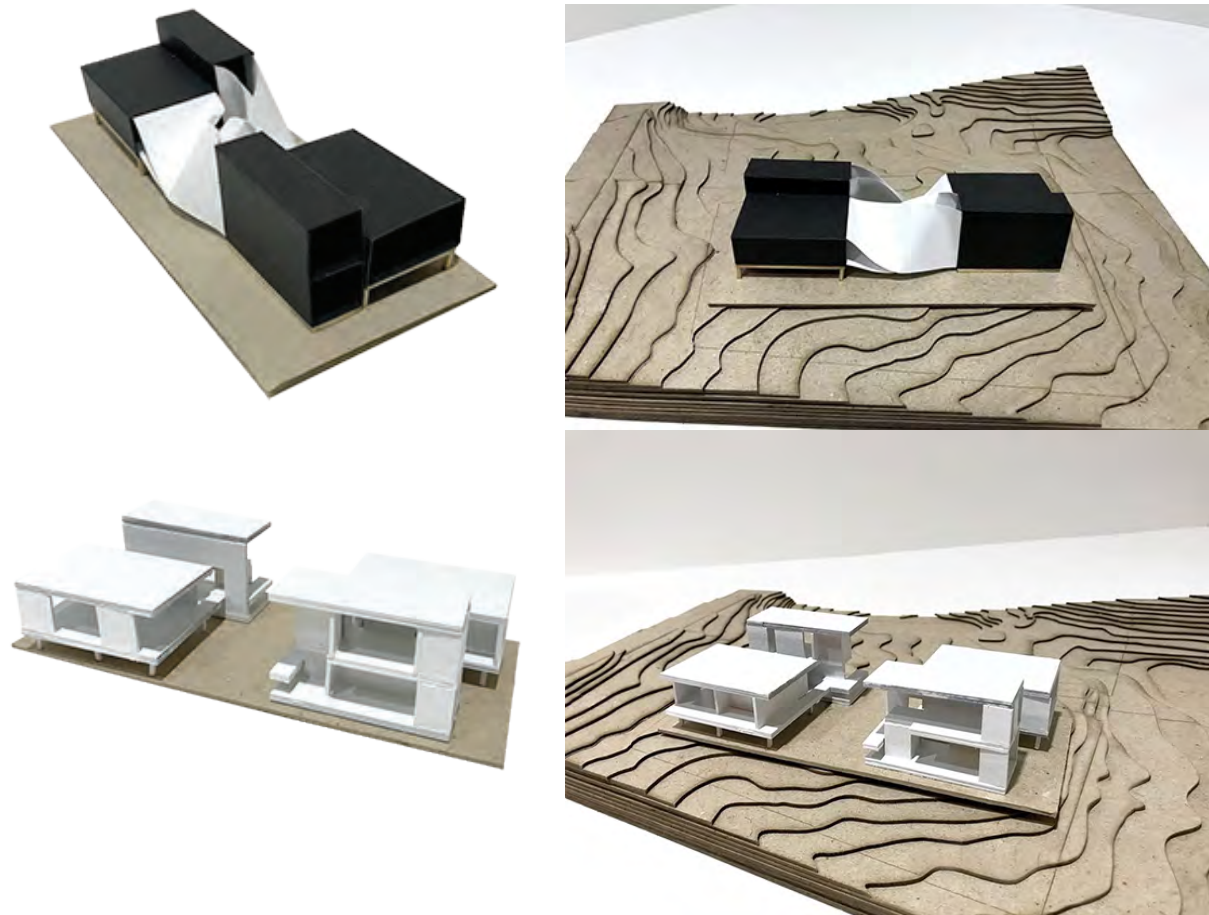

Program Analysis

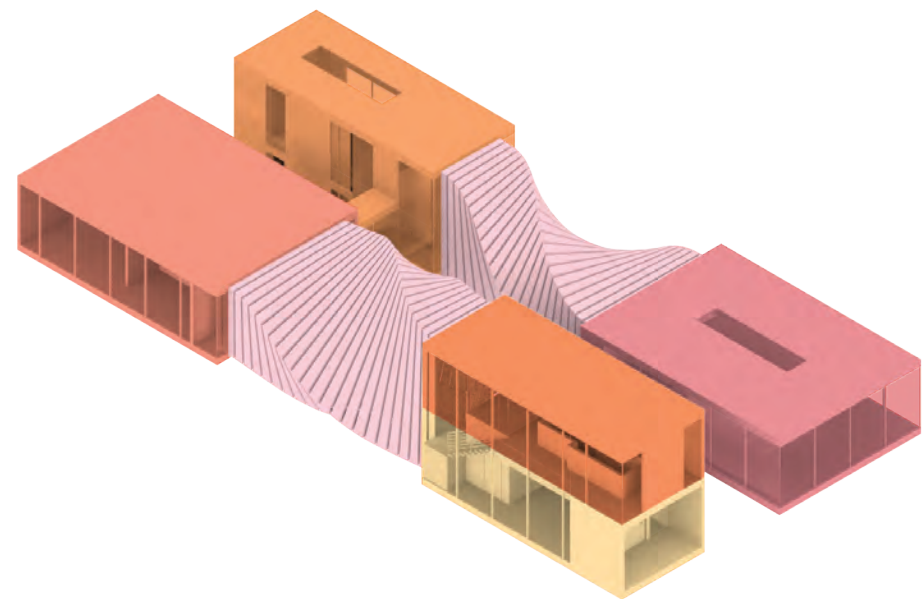

- Living room
- Master bedroom & office
- Meditation/Bridge
- Foyer
- Kitchen
- Child's bedroom
- Guest bedroom

Diagram Analysis

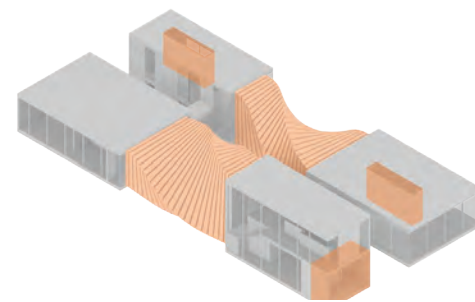

SOLID & VOID

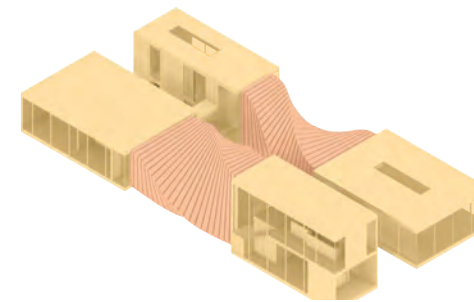

SIMPLE & COMPLEX

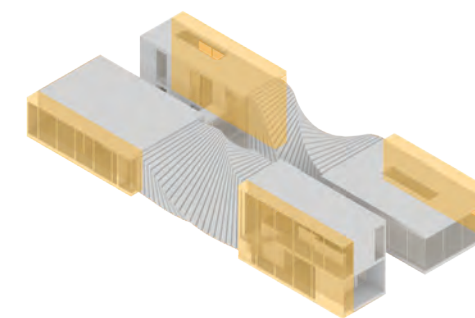

ADDITION

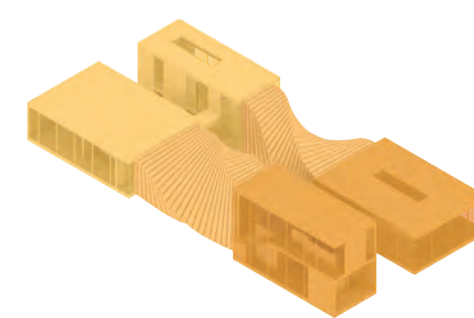

PRIVATE, TRANSITION & PUBLIC SPACES

Solar Analysis

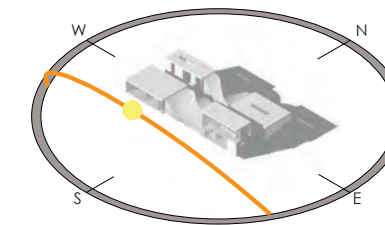

SPRING EQUINOX

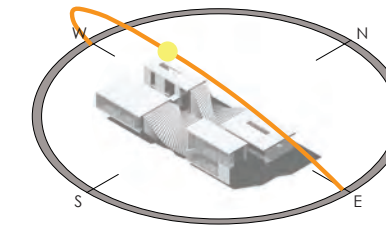

SUMMER SOLSTICE

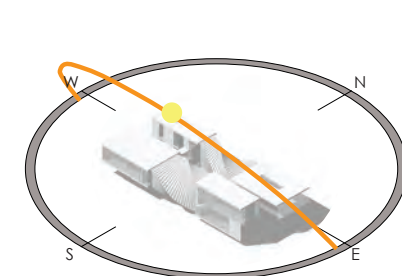

FALL EQUINOX

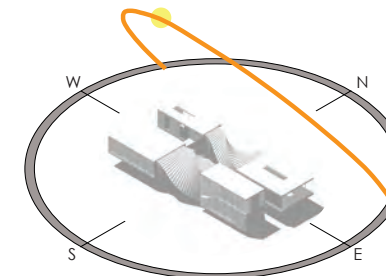

WINTER SOLSTICE

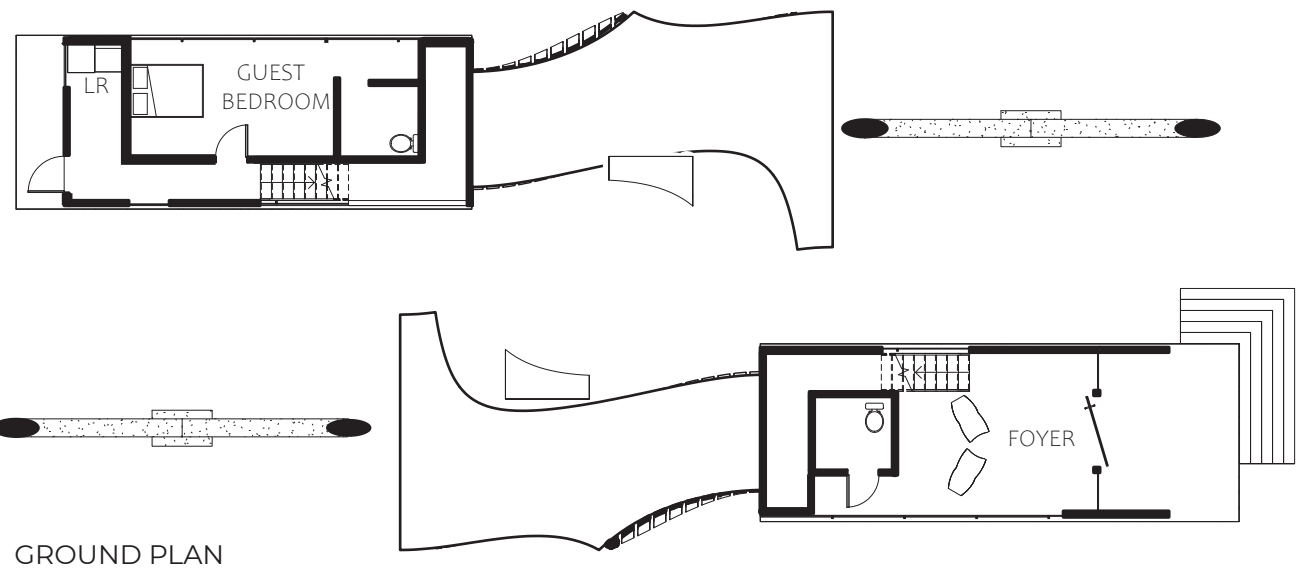

GROUND PLAN

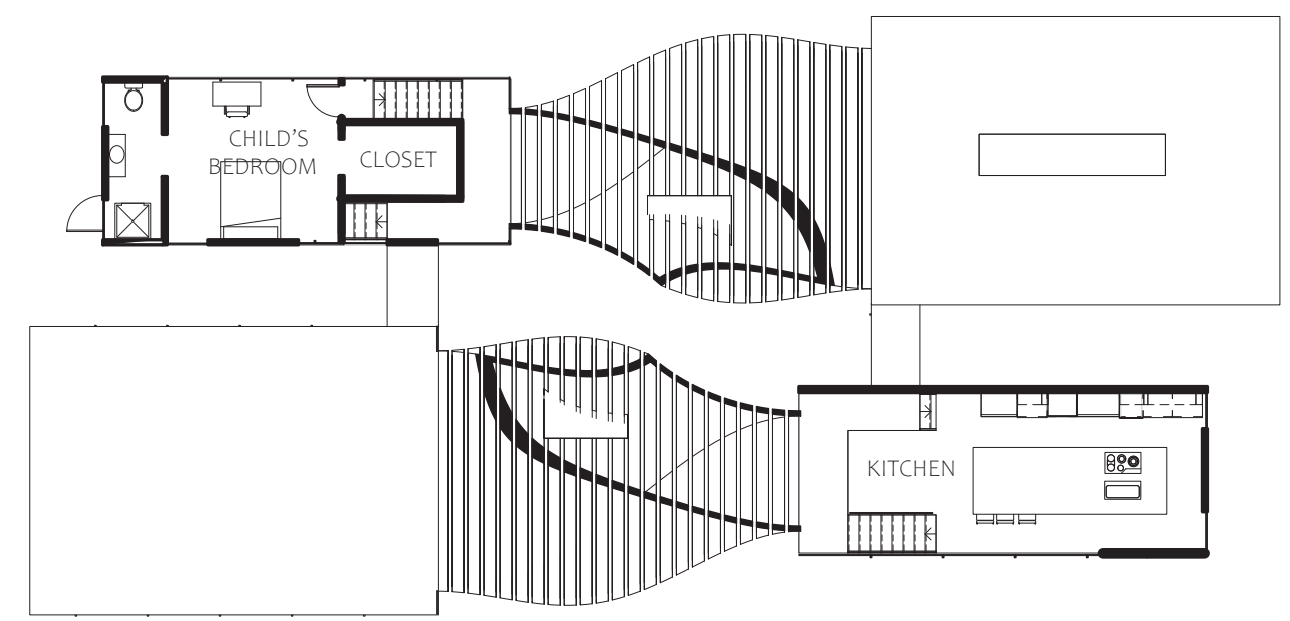

SECOND FLOOR PLAN

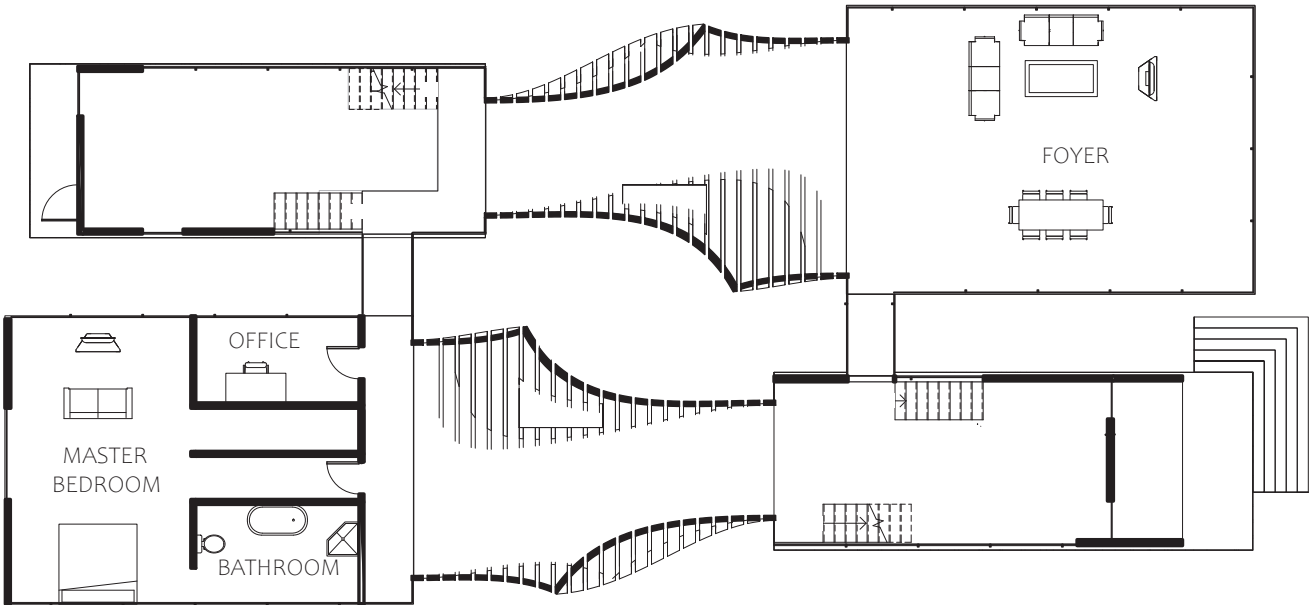

FIRST FLOOR PLAN

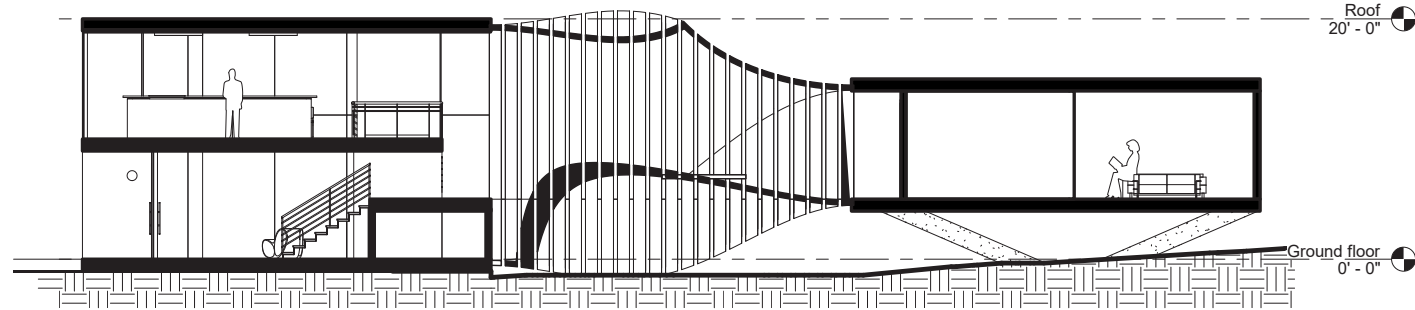

SECTION

SCALE: 1/16"=1'-0"





"An idea is salvation by imagination"
- Frank Lloyd Wright



ETECH I

Parametric Tile

In Etech I, a parametric tile was to be designed using three to four different materials: wood, plastic, foam and concrete. The design process starts with the pattern. The tile constraints were 15"x15" and the thickness 2". The A second variation of the tile had to be made, an inverse. The purpose of this inverted tile was to build the concrete.

The wood and foam tiles were built by the CNC machine. To create the plastic tile, the foam tile was drilled at different points and placed in a vacuum forming machine. The inverted wood tile was used to mold the concrete tile.

ORIGINAL TILE

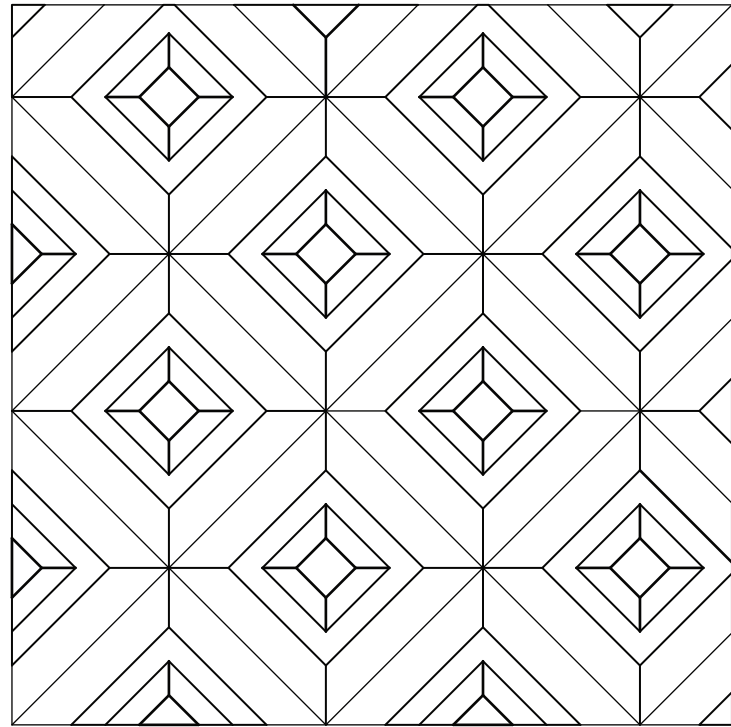

PLAN

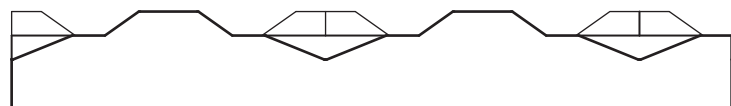

SECTION

INVERTED TILE

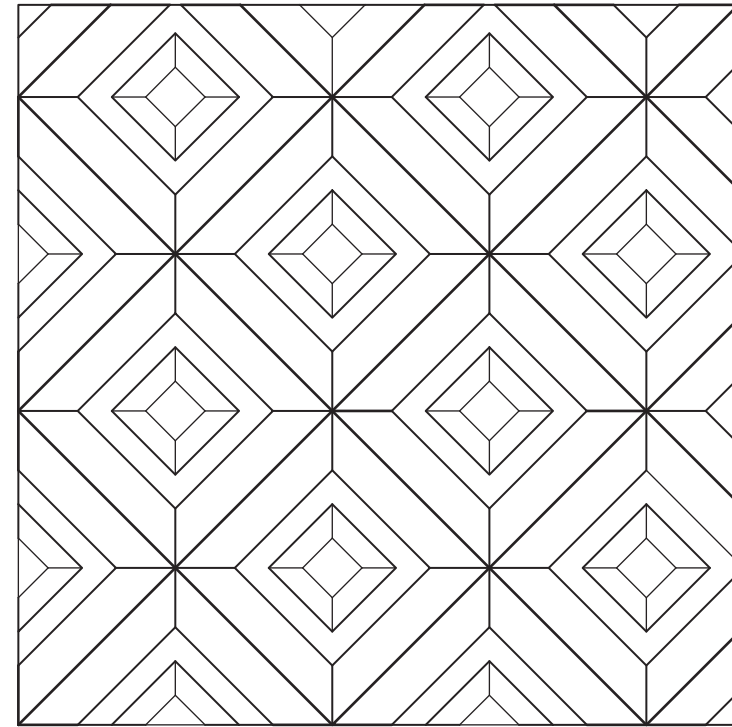

PLAN

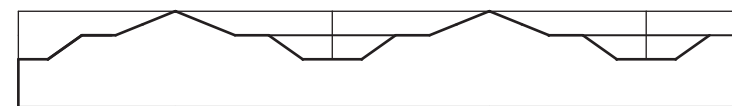

SECTION

SCALE: 3"=1'-0"

Fabrication Process



CNC machine carving the wood tile



A drill press performing on a foam tile



A cement mixture in preparation for the molding

Final Models



WOOD TILE PAINTED WHITE



CONCRETE TILE



PLASTIC TILE



FOAM TILE

"We shape our buildings; thereafter they shape us"
- Winston Churchill



DESIGN
COMMUNICATION II

Encuentro Guadalupe

The Encuentro Guadalupe was the precedent study for Design Communication II. This is a series of cabins located in Valle de Guadalupe, Baja California. It was designed by graciastudio, Architect Jorge Gracia. In this class, we were introduced to Revit, an architecture software, and learn more about Adobe Photoshop and Illustrator. The material of the structure of was corten steel which erodes aesthetically and blends into the environment.

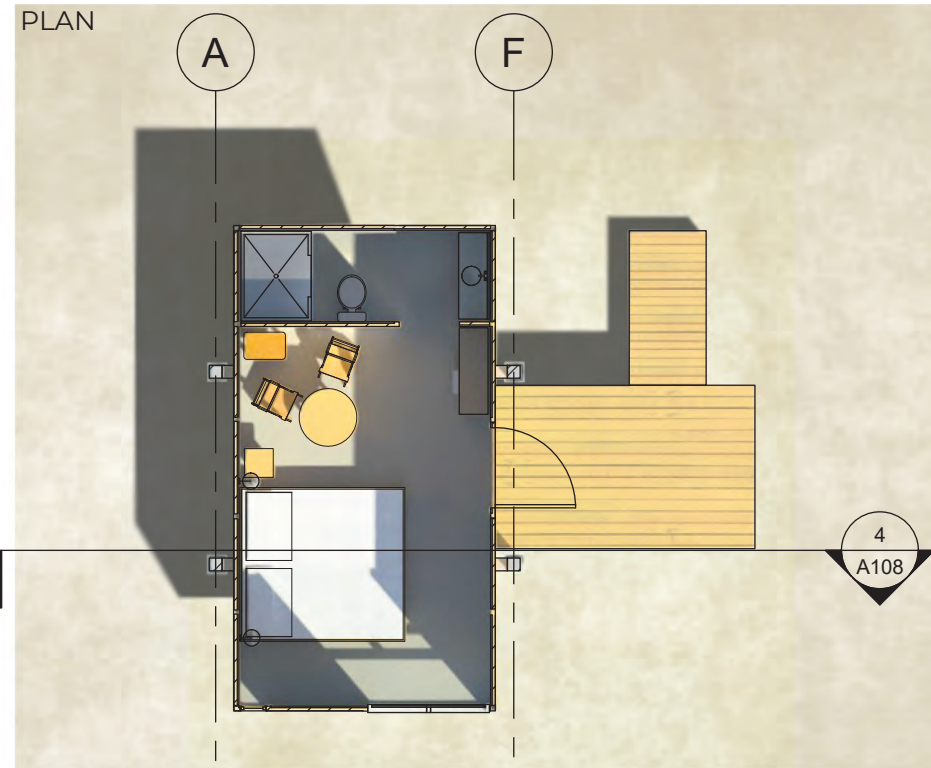

ELEVATION

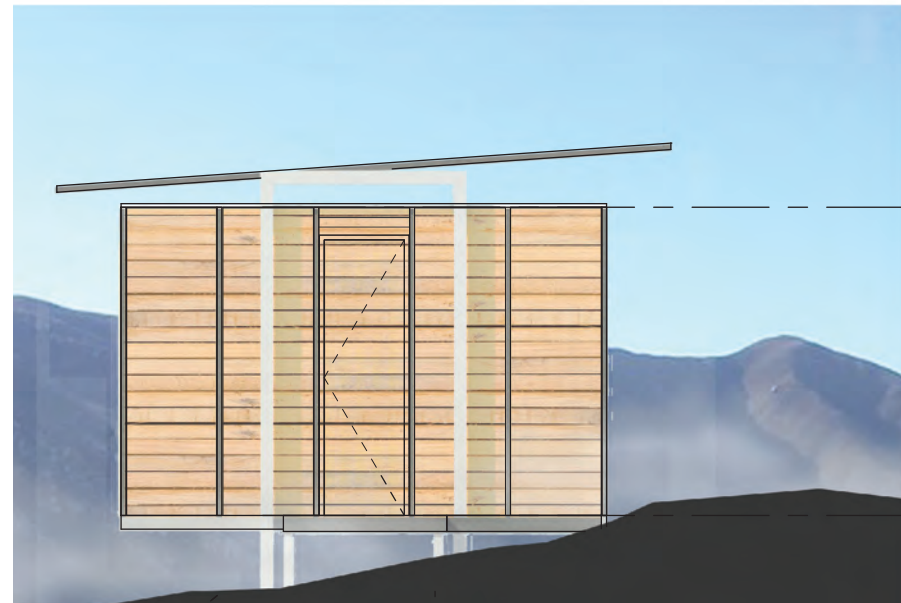

SECTION

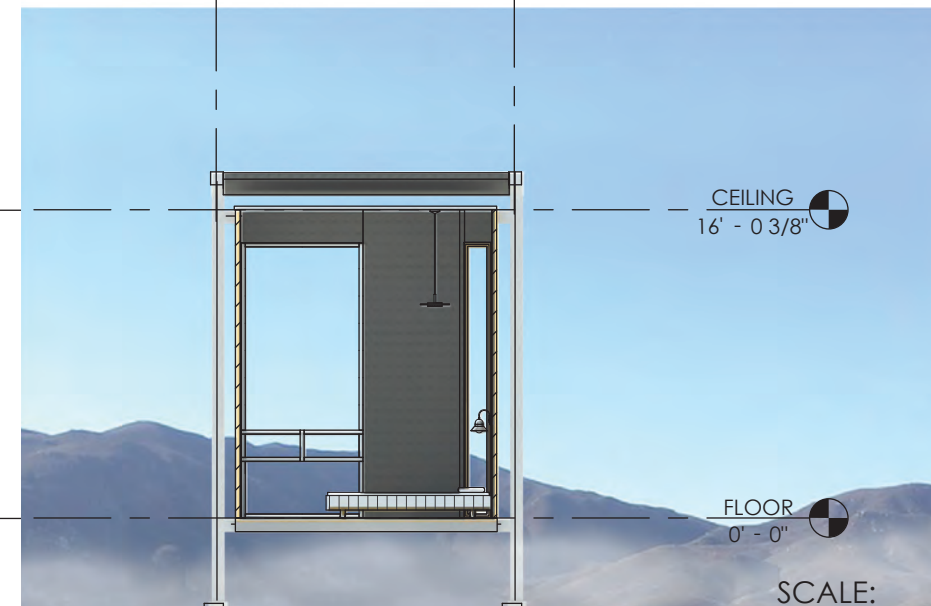

EXPLODED AXONOMETRIC

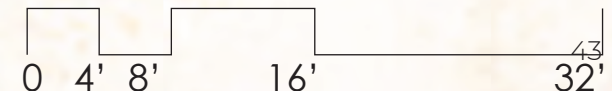
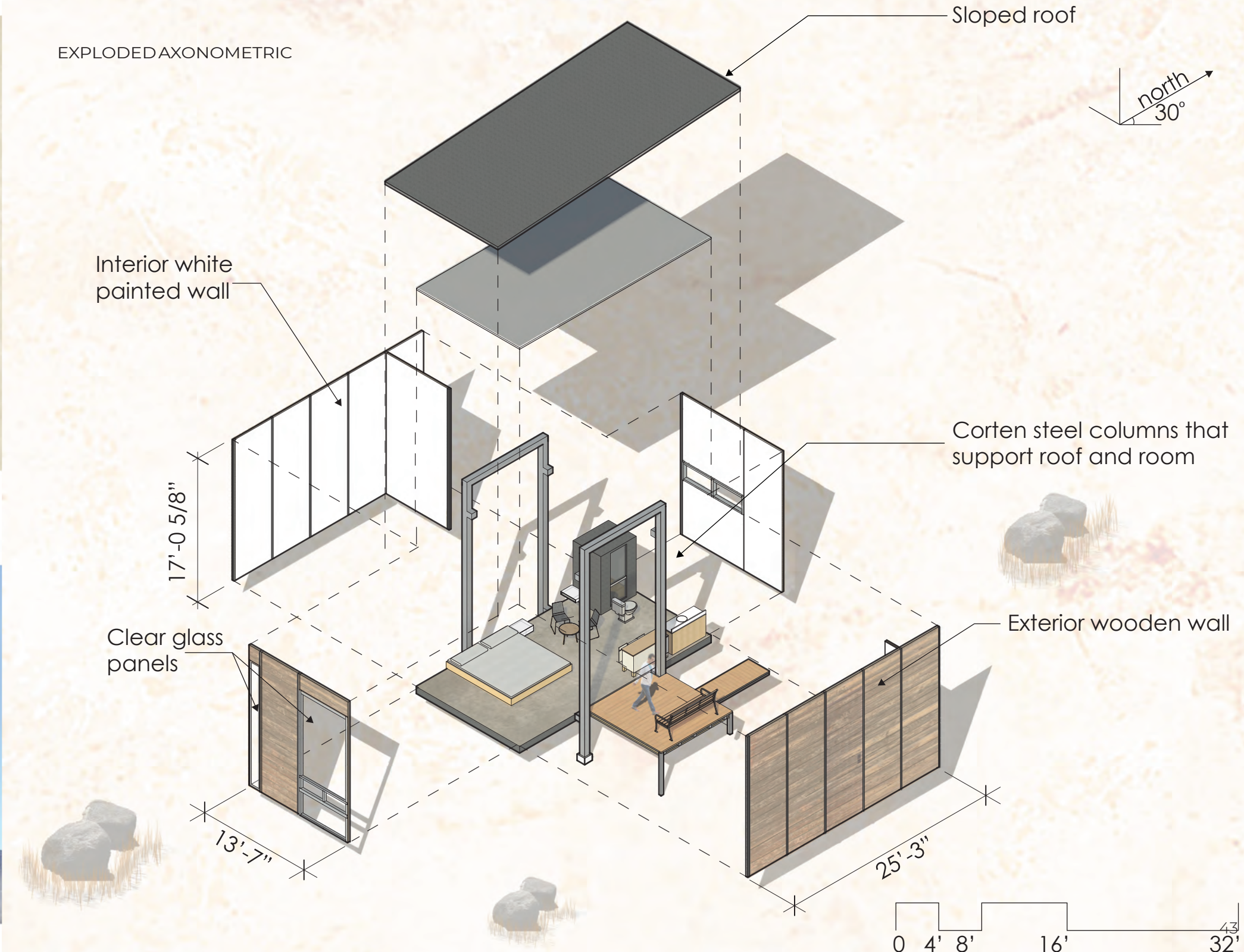

Wall Section Detail

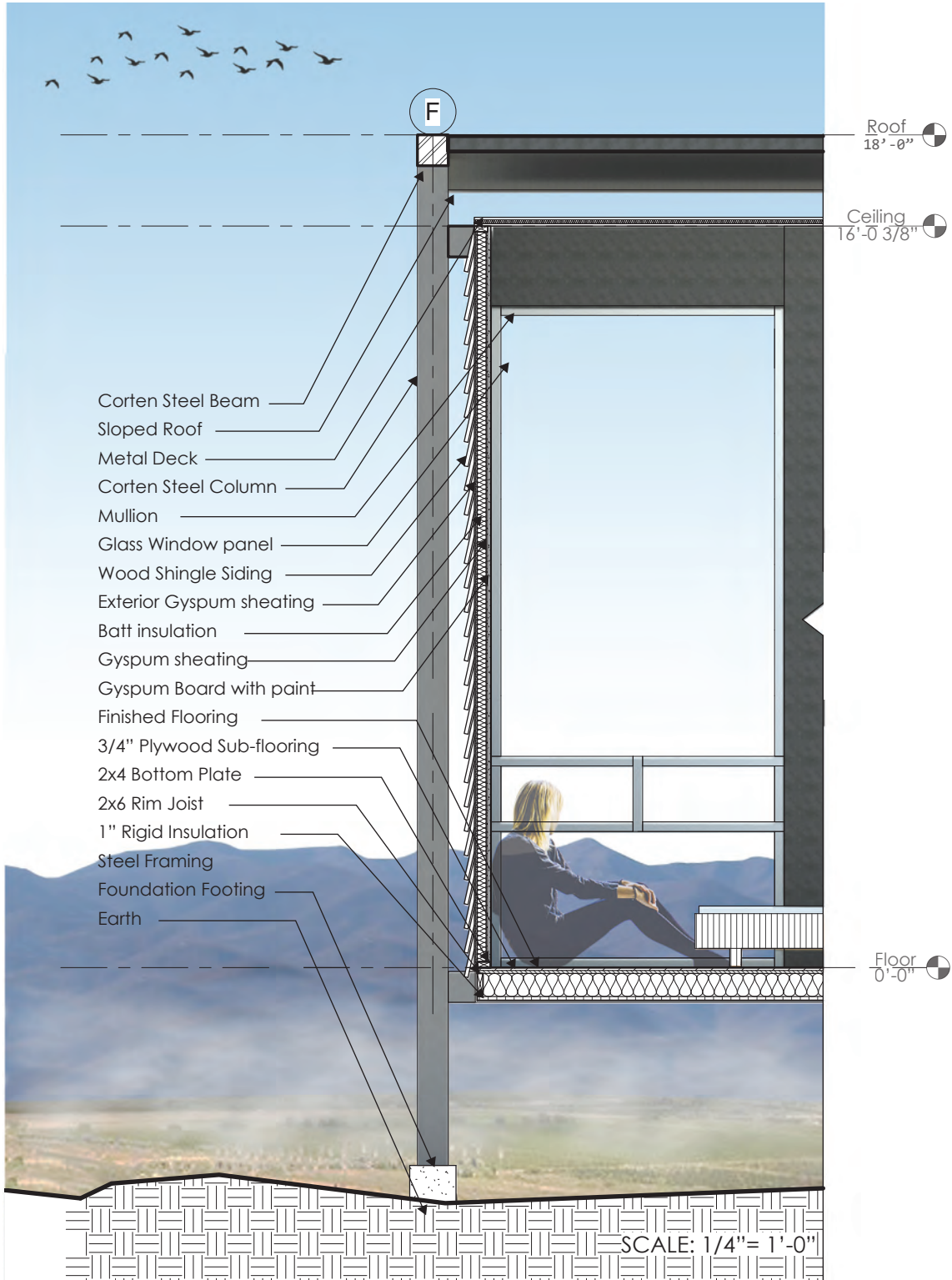

"God is in the details"
- Ludwig Mies van der Rohe



STUDIO IV

A Modular System

This design outcome of this project was to make a modular system that interacts with an element of nature. The chosen element in this project was water. To help the design development, the idea of it being a facade was at the forefront.

Shape and Pattern analysis

This is a stylized image of a reptilian skin. The common shape is a rectangle. The dots represent the number and sizes of shapes in the image. The second series of abstraction focused on density. Density has range that allows diversity and exploration.

The second abstraction is a close-up image of a fiber material. The darker and thicker lines show that pathway function as the main structure and line of connection.

The last abstraction is a series of abstraction. It is an image of a part of a coral reef. The abstraction shows one primary and one secondary shape.

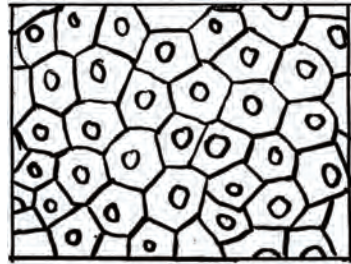
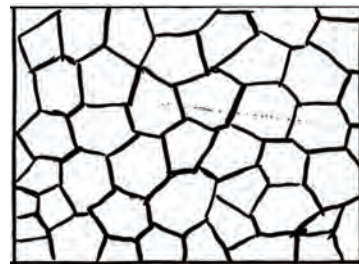
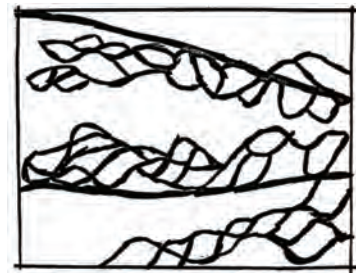
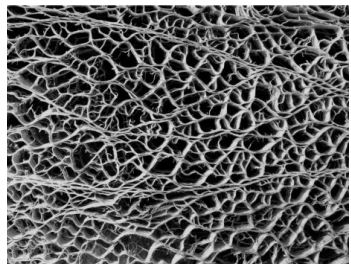
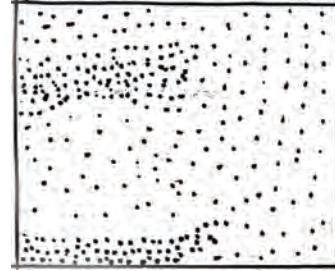
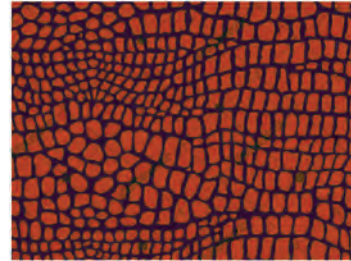

Module Development

The hexagon shape was the shape derived from abstraction. The hexagon is one of the most common shapes in nature and has a sense of balance.

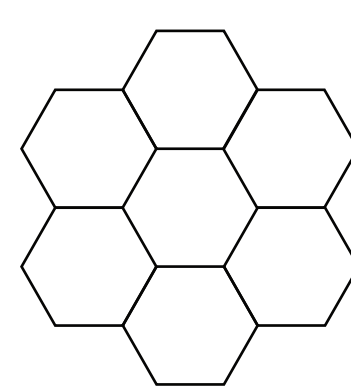

A 2-Dimensional drawing of the module

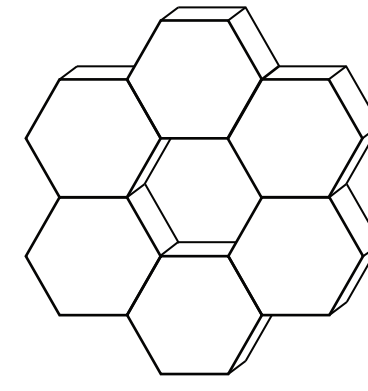

A 3-Dimensional drawing of the module

One of the goal of the project is to interact with water. By tapering the module, it creates a possibility of forming an interaction with water.

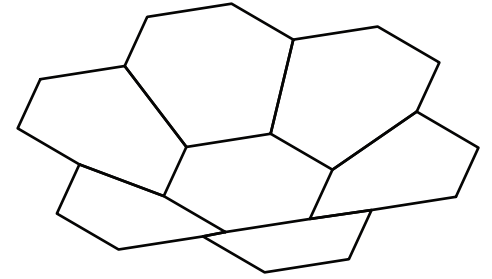
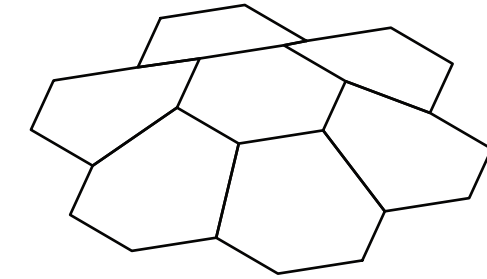

Pattern Development

A series of patterns were develop to decide which best fit the module. The dark hexagons will function as connection between all the modules.



PATTERN 1



PATTERN 2



PATTERN 3

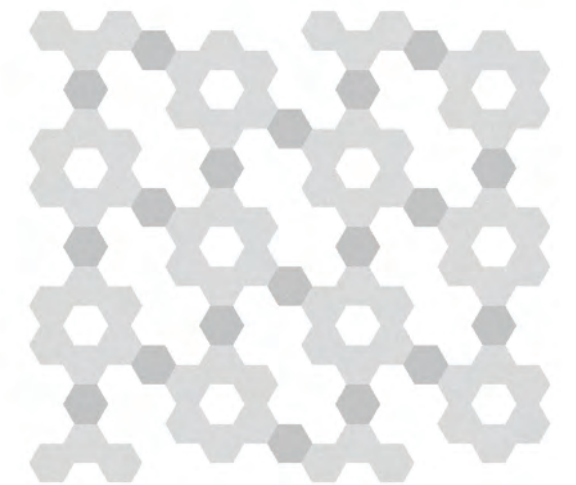

FINAL PATTERN

System Development

The system was developed from the pattern. The spaces within the pattern formed the different layers of the system. The dark hexagons that function as a connection are extruded into a rod and connect all the different layers.

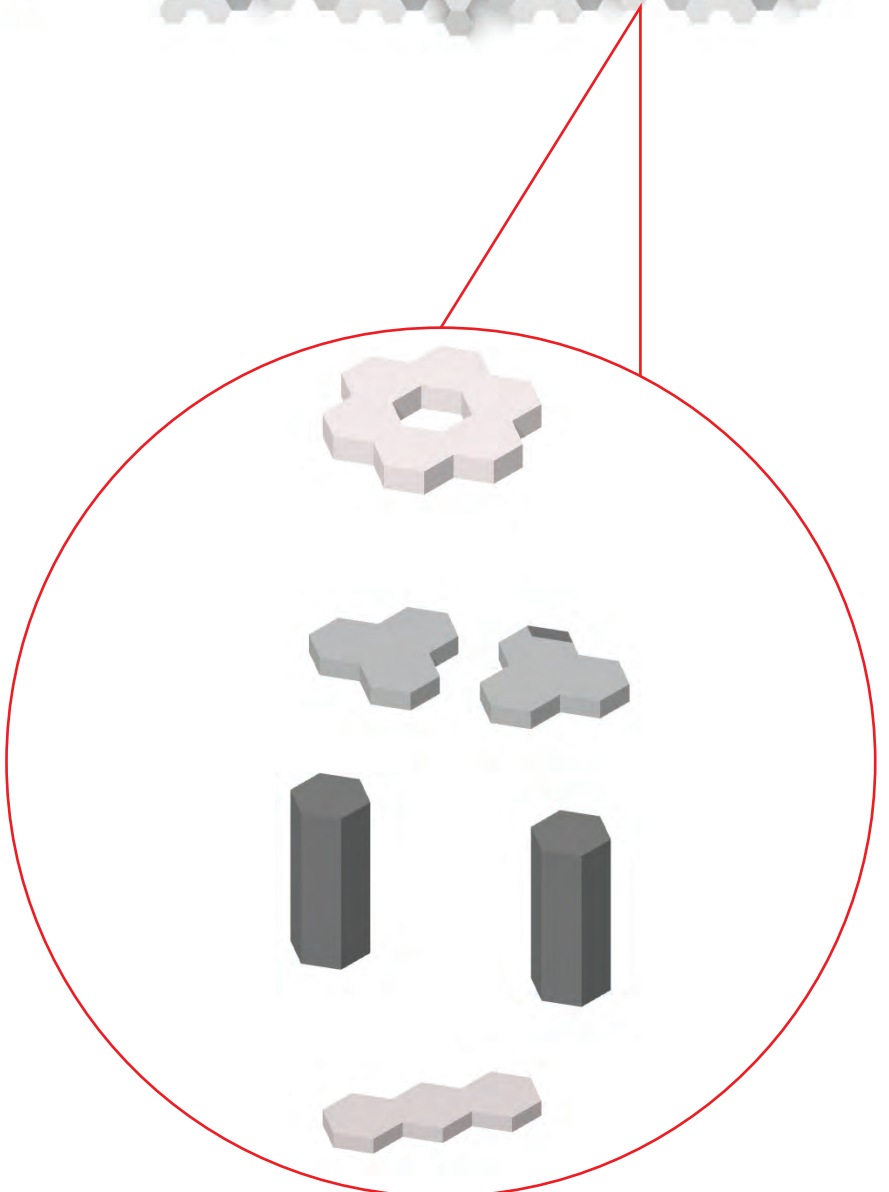
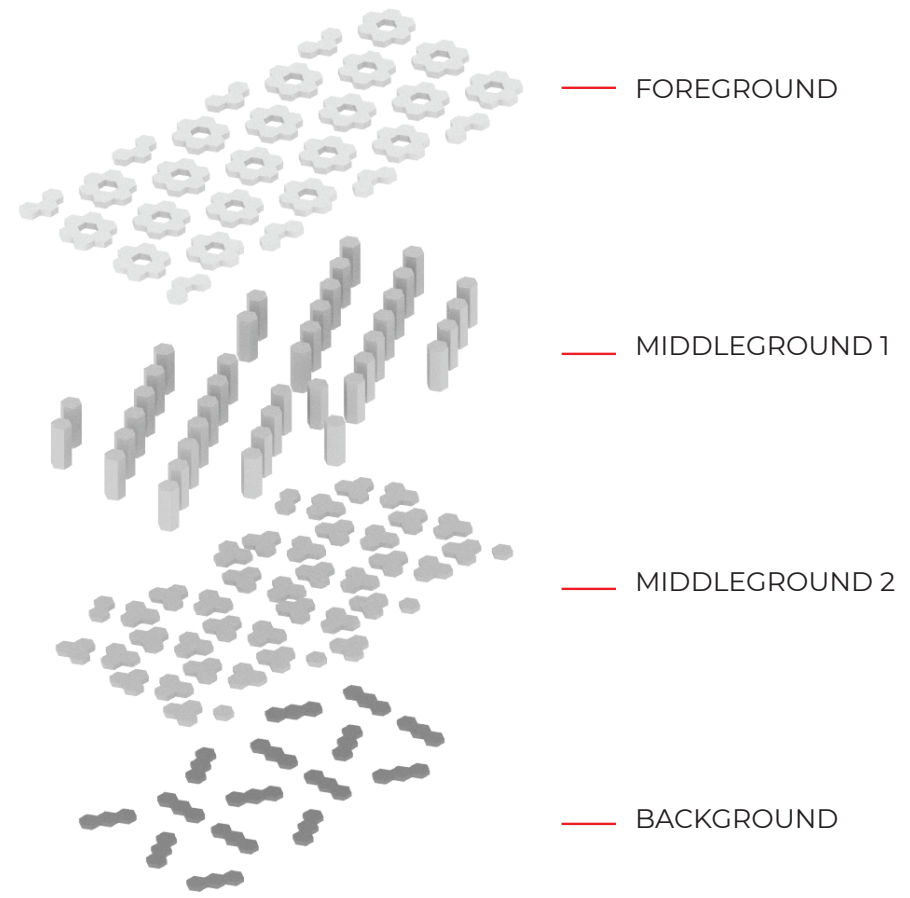
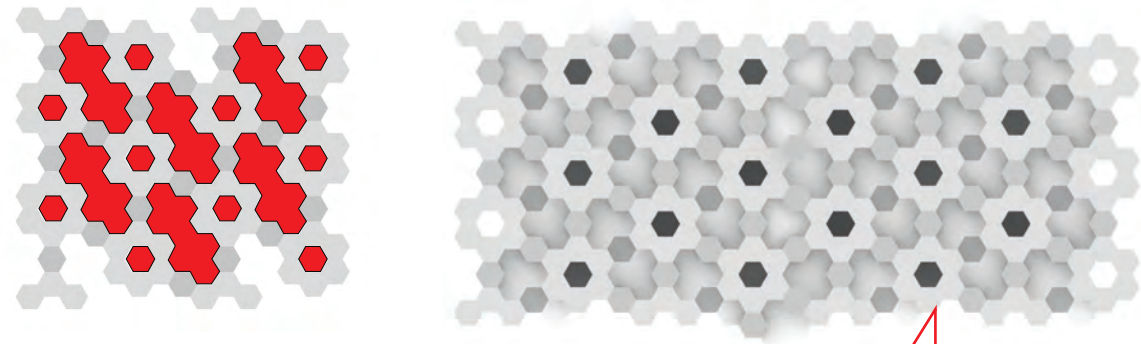

Final Module System Development

The overall module system still needed to be iterated to further improve the interaction with water. The rods and the foreground module were iterated by using a tapered movement.

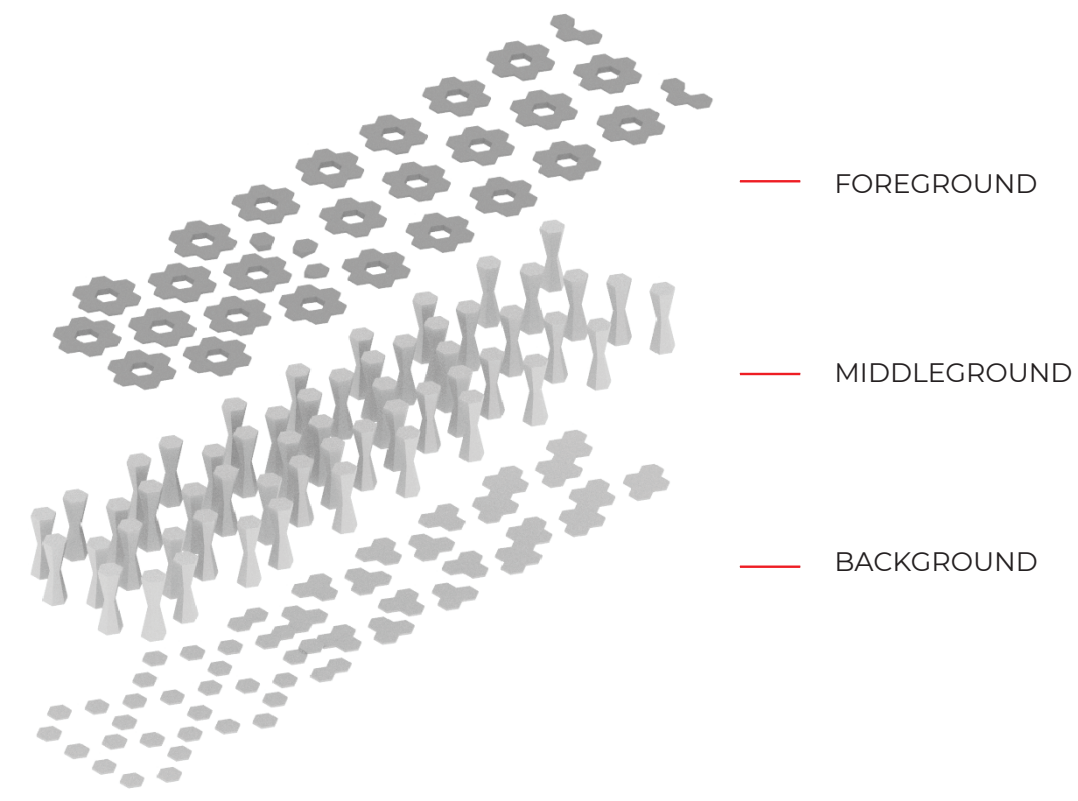
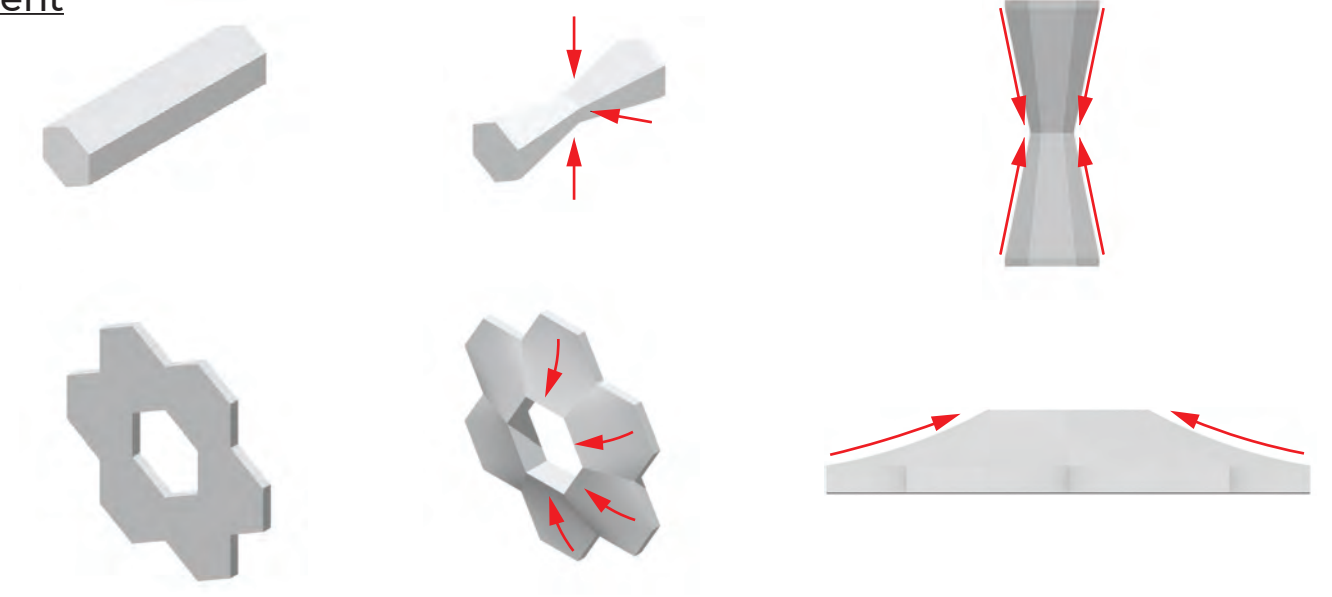

The second series of abstraction influenced the pattern arrangement of the module. The density changes from dense to sparse. This creates diversity in views and interaction with water.

Assembly and Water Interaction

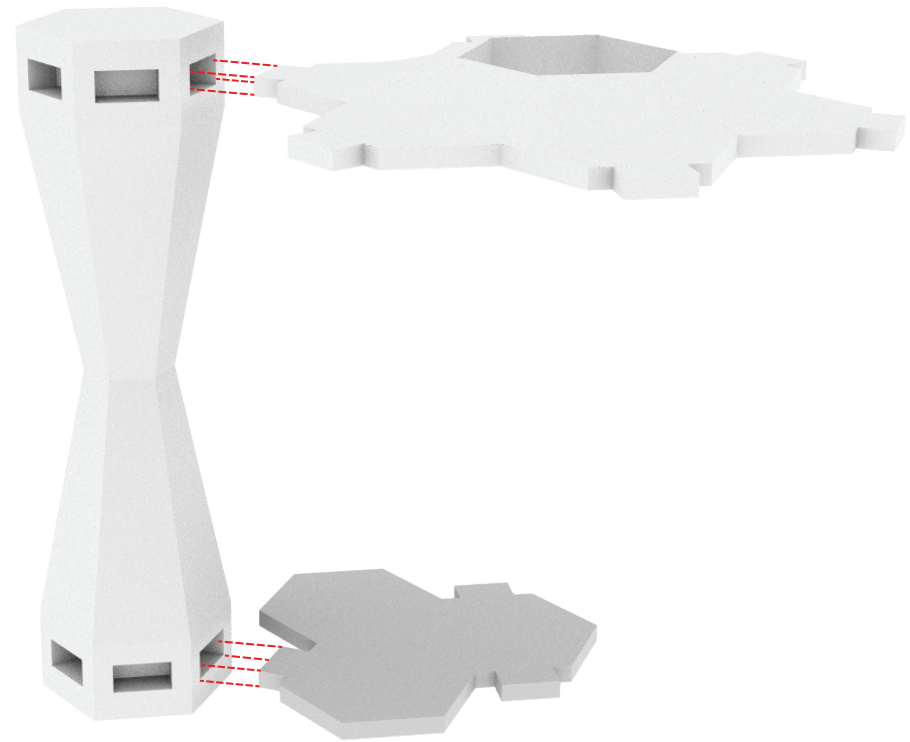

The red line show the line of joinery. It is a mortise and tenon type of joint.

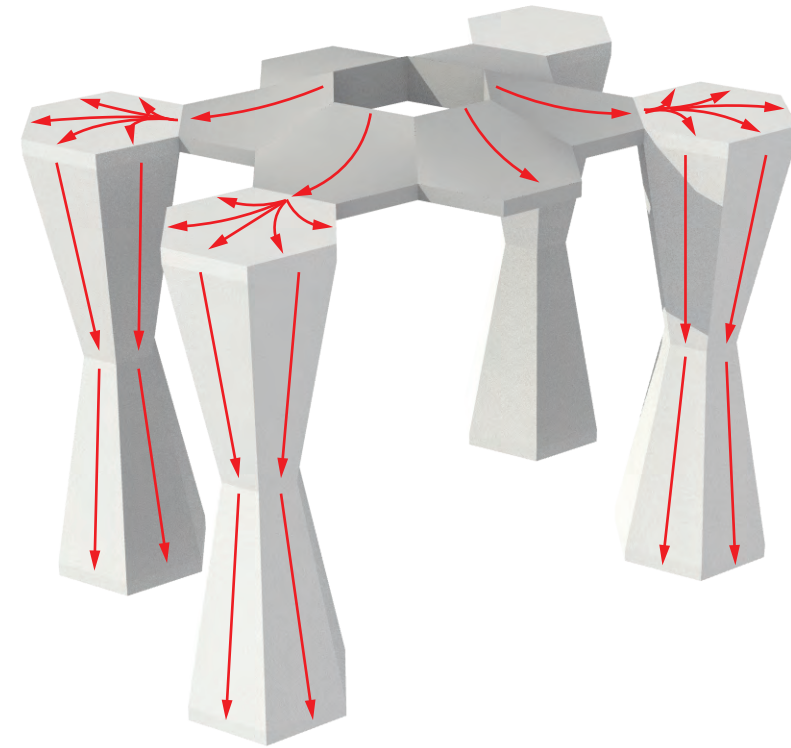

The red arrowhead lines show the direction of water flow

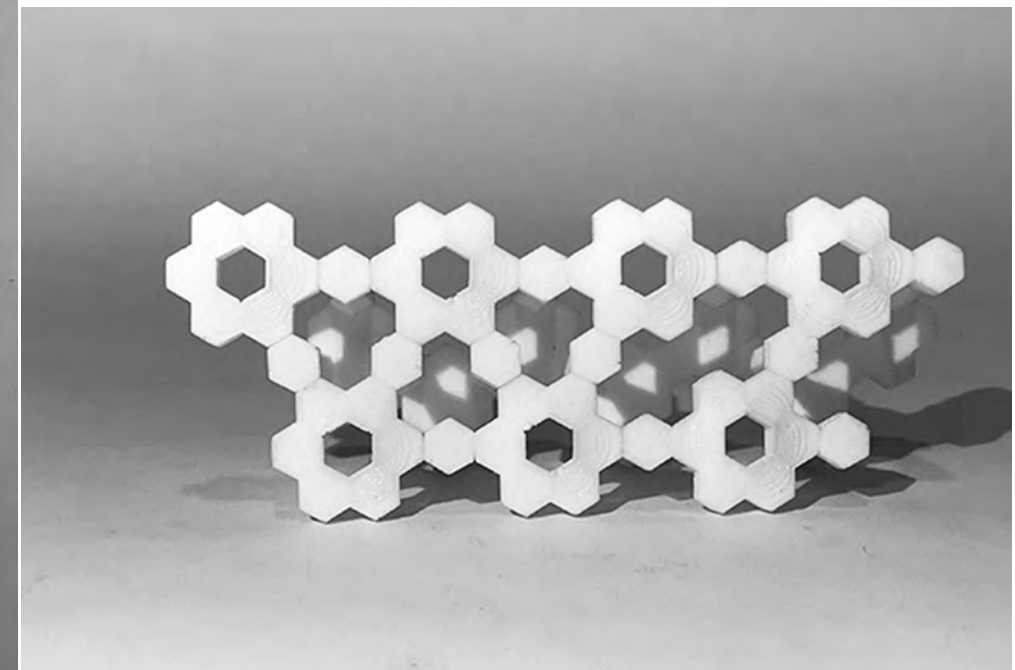
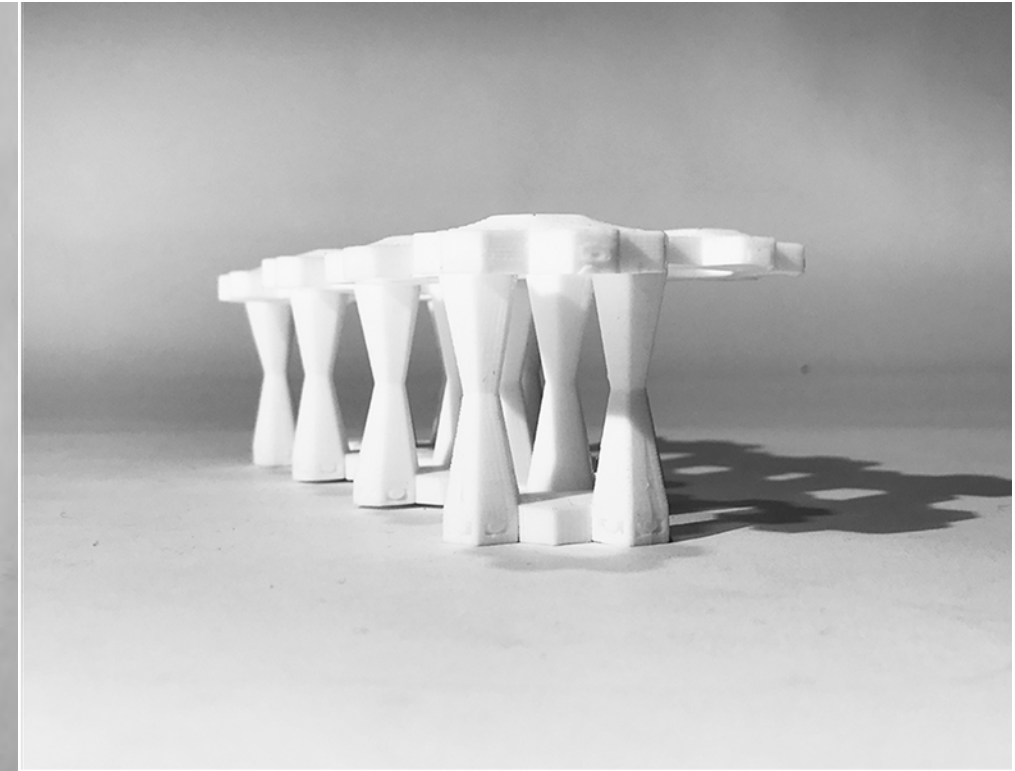
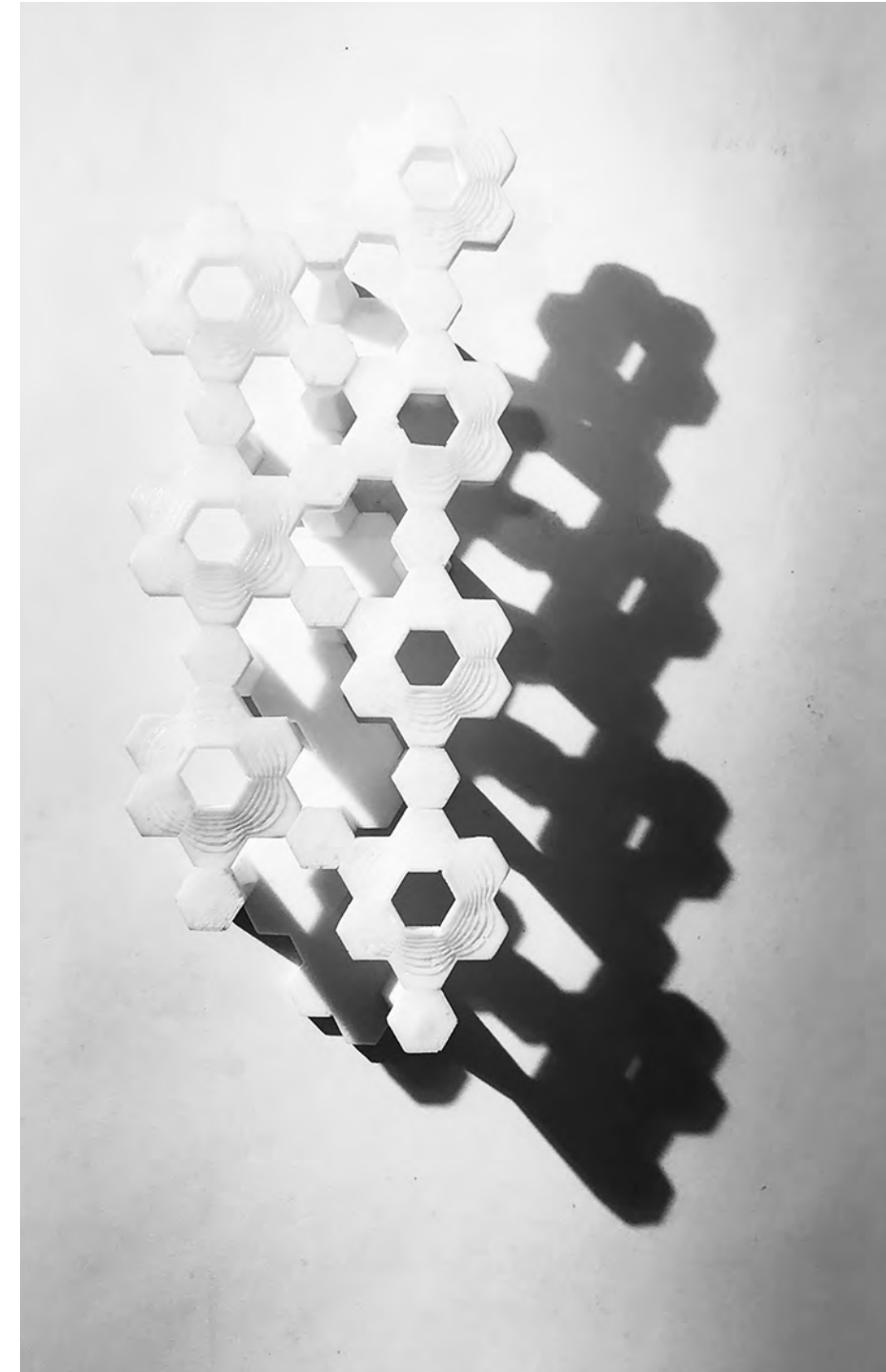

*"In pure architecture the smallest detail
should have meaning or serve a purpose."*

- Augustus W.N. Pugin

Thank You

