

## Using the Picademy Parts Kit Temperature Probe

The temperature probe is different from the other sensors. The others provide on/off signals, while the temperature probe sends a stream of data. The probe is based on the DS18B20 sensor and sends a digital signal that is the Celsius value of the temperature.

### Configuring the Software

If you're using a KSU Workshop image with a release number of 19-102 or higher, the temperature probe software is already configured. (The release number is on the desktop wallpaper in light gray, just under the Kennesaw State banner. You can also find it by typing `cat /etc/issue` in a terminal window.)

If you started with "vanilla" Raspbian, you must install the software and enable the 1-Wire interface. To install the software, open a terminal window and type:

```
sudo pip3 install w1thermsensor
```

 An Internet connection is required.

To enable the 1-Wire interface, click the Raspberry at the top left, then Preferences → Raspberry Pi Configuration. Click the Interfaces tab, select the Enable button next to 1-Wire, then OK. Allow the configuration software to perform a reboot.

By default, the 1-Wire interface uses GPIO pin 4. Unlike the other devices, the pin number is not specified in the Python code. You should not need to change this, but if you do, you will need to edit the `/boot/config.txt` file, find the line that says `dtoverlay=w1-gpio` and change it to `dtoverlay=w1-gpio,gpiopin=x` where `x` is the pin you want to use, then reboot.

### Wiring the Circuit



**This circuit must be attached with the Raspberry Pi turned off.** Check your wiring very carefully because incorrect wiring can damage your Raspberry Pi. If you do this in class, consider asking students to check each other's work. The colors for wires given here are *only* for the probe in the Picademy parts kit. If your probe came from elsewhere, *be sure* you know which color goes to which pin.

The temperature probe has three leads made of stranded wire, which is difficult to attach directly to the breadboard. Your parts kit contains a connector block for attaching the wires. Loosen the screws on the top of the connector block, insert the wires in the openings on the side, and tighten the screws. Note that the pins on the bottom of the connector block go into *every other* hole in the breadboard.

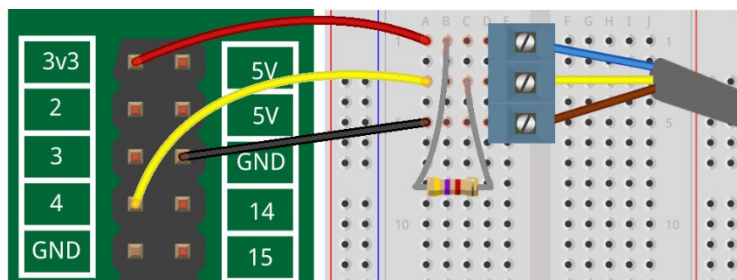

This work incorporates material developed by the Raspberry Pi Foundation, used under the Creative Commons BY-SA license.

This work is copyright © 2018 by Kennesaw State University and is licensed under the Creative Commons BY-SA license.



The wire colors are brown-GND, yellow-data, blue-3v3. There is a 4.7K $\Omega$  resistor (yellow-violet-red) connected between 3v3 (power) and data. The 1-Wire software expects the device to be connected on pin 4 as shown in the illustration. Unlike the other devices, the pin number is not specified in the Python code. (You should not need to change this, but if you do, see *Configuring the Software* above..)

When you have installed the software, if necessary, and wired the circuit on the breadboard, power down your Raspberry Pi, connect the GPIO pins to the breadboard, and power up.

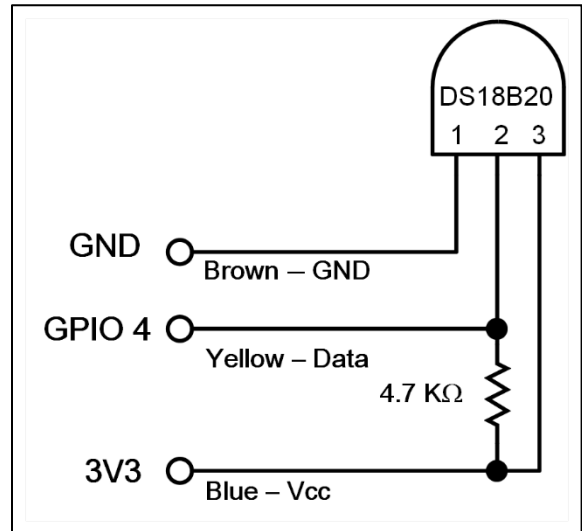

There is some overly complex code for the temperature sensor on the web. Here is what you need.

```
# Read and print the temperature at the probe
from time import sleep
# Import the ThermSensor library - Note the capitalization!
from w1thermsensor import W1ThermSensor
sensor = W1ThermSensor()

while True:
    temperature = sensor.get_temperature()
    F = temperature*1.8+32 # Convert Celsius to Farenheit
    F = round(F, 2) # Round to two decimal places
    print("The temperature is %s" % F) # Print with formatting
    sleep(1)
```

**If you get error message** *"No unknown temperature sensor with id ' ' found"*

1. Check that the resistor used is 4.7 k Ohms, yellow-violet-red.
2. Check wiring. Especially note that the breadboard connector uses *every other* bar.